

AES Group, Inc.

Sales • Construction • Service

**Dekker VMX0036MA2-40-DS
Laboratory Vacuum System
Equipment**

Submittal Information

AES Group, Inc.

Sales • Construction • Service

- AES-Dekker Medical-Laboratory Vacuum System Model AES-VMX0036MA2-40-DS
 - (2) Dekker Titan single stage 3HP liquid ring vacuum pump skids.
 - **Capacity each vacuum pump 11.7 SCFM @ 20" HGvac.**
 - System Components Include:
 - (2) TEFC Electric motors, 230/460 Volt, 3 Phase, Premium Efficiency.
 - (2) Flexible Couplings
 - (2) Fabricated Steel Baseplates
 - (2) Patented DX5 Discharge Separator-Reservoirs with 5 Stage Air/Oil Separation, Including Coalescing Filter.
 - (2) Seal Fluid Isolation Valves
 - (2) Y-Strainers
 - (2) Separator Drain Valves
 - (2) Separator Sight Level Gauges
 - (2) Temperature RTD for Discharge Temperature Indication and High Temperature Protection.
 - (2) High/Low Oil Level Switches
 - (2) Air-Cooled, Heat Exchanger Packages with Main Motor Driven Fan and Fan Guard.
 - (2) Inlet Check Valves
 - Inlet Manifold Including:
 - (2) Inlet Isolation Valves
 - (2) Inlet Flex Connectors
 - Manifold Piping
 - Discharge Manifold Including:
 - (2) Individual Pump Drip Legs
 - (2) Discharge Check Valves
 - (2) Discharge Flex Connectors
 - Manifold Piping
 - (2) Sets of Hydraulic Hose Seal Fluid Line.
 - (2) Inlet Filters
 - (2) Inlet Filter Silencers
 - (2) Vacuum Relief Valves
 - Vacuum Receiver
 - Horizontal Grasshopper Vacuum Receiver 80 Gallon.
 - Receiver Isolation Valve
 - Receiver Sight Level Gauge
 - Receiver Drain Valve
 - (1) Dekker NEMA 12, UL Listed, 2015 NFPA Compliant Duplex Control Panel
 - 460V, 3-Phase, 60Hz, NEMA 12, UL Listed
 - Dual Power Feed with Circuit Breaker Disconnects
 - (2) Power Supplies
 - Fused Disconnect
 - Across The Line Magnetic Vacuum Pump Starters with 3-Phase Overload Protection and Through the Door Reset Switches
 - HOA Selector Switches
 - Hour Meters
 - Pump Running Lights
 - Audio/Visual Alarm to Signal Lag Vacuum Pump Operation
 - Micro Processing Controller. Includes Frequent Start/Stop Protection and Automatic Pump Alternation.
 - Vacuum Transducer
 - Auxiliary Dry Contacts
 - System Fault Light (RED)

*4330 Redwood Highway, Suite 100
San Rafael, CA 94903
Tel 415 507-9373 Fax 415 507-9376*

SYSTEM APPROVAL
 APPROVED BY:
 DATE:

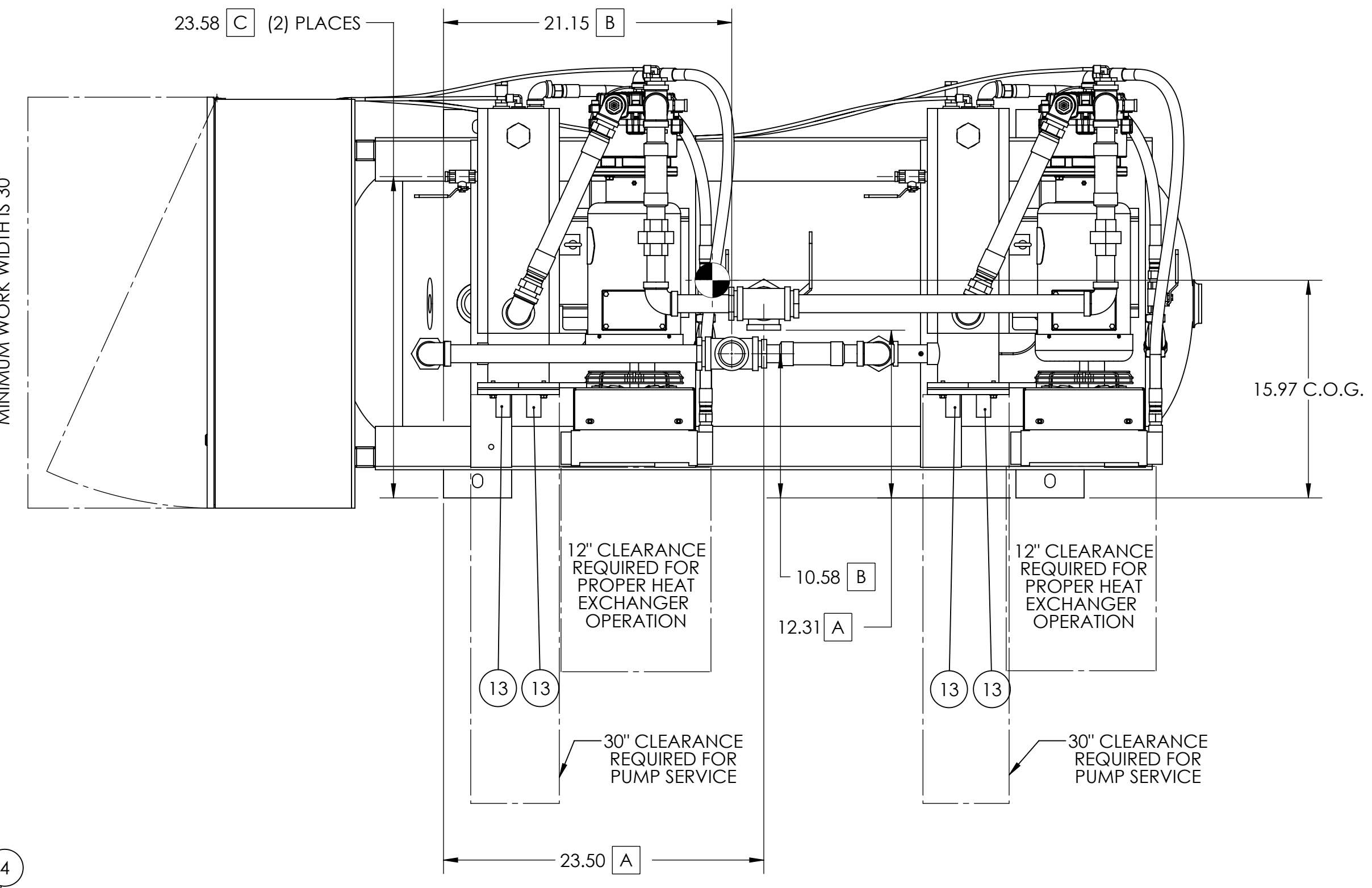
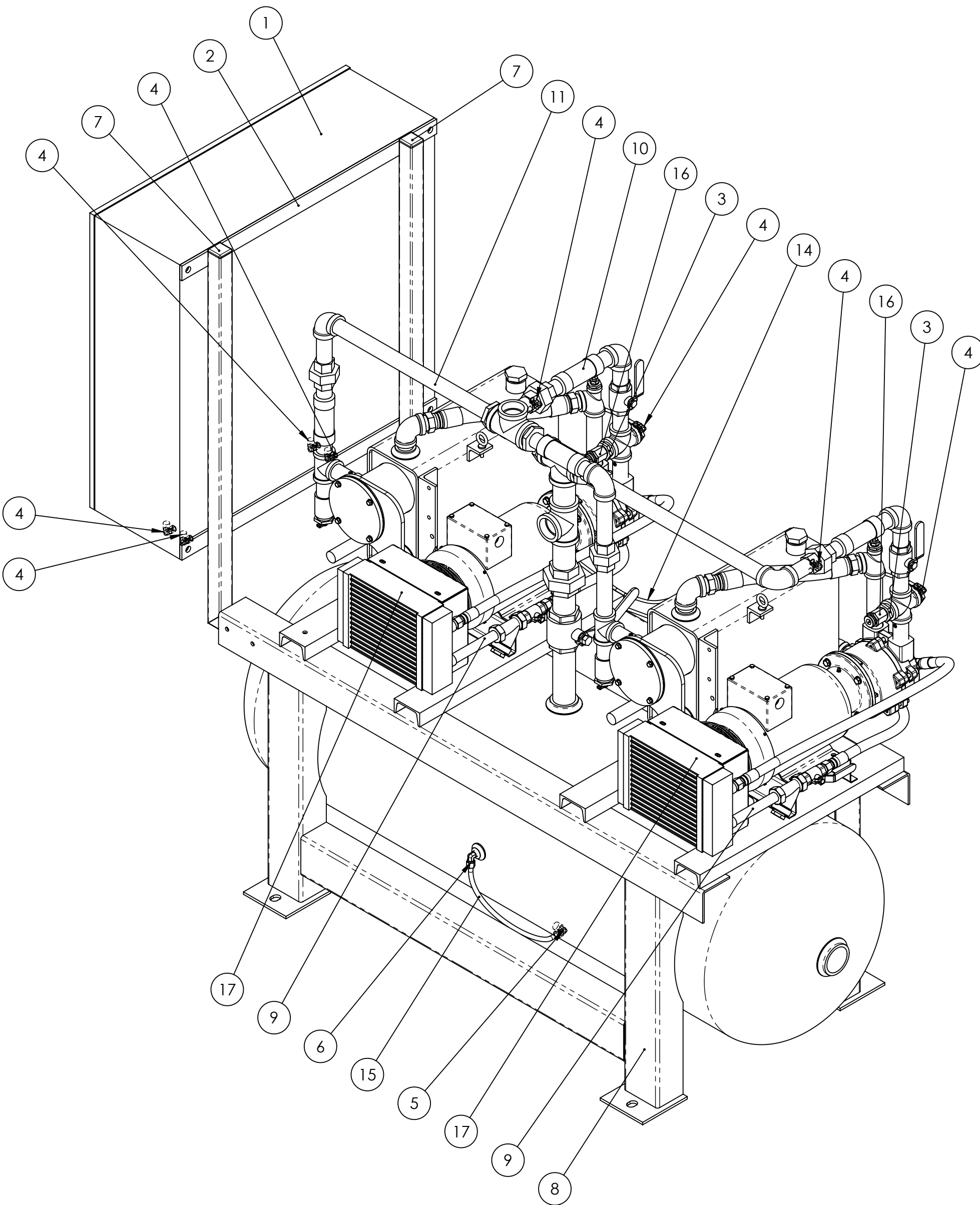

078284				
ITEM NO.	QTY	LENGTH	DESCRIPTION	PART NUMBER
1	1		MEDICAL CTRL PNL 3HP DUPLEX VMAX 460V	2202-0782-840
2	1		BRACKET CNTL PNL 30X30X10	2730-2017-921
3	2		BUSHING 1.0"MNPT X .75"FNPT CS	3002-1075-0
4	8		FTNG 90° .25"MNPTX.25"UBE BRS PUSH	3039-0025-001
5	1		FTNG 90° .38"MNPTX.38"UBE BRS PUSH	3039-0038-000
6	1		FTNG 90° .25"MNPTX.38"UBE BRS PUSH	3039-2538-000-R
7	2		PLUG PROTECTIVE 1.5" SQR POLY	3842-0150-000
8	1		RCVR TNK HRZ 80G CS GRASSHOPP MOD	6008-0080-001
9	2		SUB ASSEMBLY PIPING VMX0036M AIRCOL	6870-0036-011
10	1		SYSTEM INLET MANIFOLD	6890-076156-1
11	1		SYSTEM DISCHARGE MANIFOLD	6890-076156-2
12	1		TANK DRAIN	6890-2013-053007-3
13	4		SWITCH LEVEL 1" MNPT N7 BRS/SST/GOLD	6910-0100-007
14	1	240	TUBING .25"OD FEP/TEFLN TRANSLUCENT	7200-0025-001
15	1	18.25	TUBING .38" OD FEP/TEFLN TRANSLUCNT	7200-0038-001
16	2		VALVE VAC RELIEF .75" ADJ 50 SCFM	7342-0075-000
17	2		VMAX 35 CFM SYSTEM 3HP MTR MOUNT	VMX0036MA1-11

SYSTEM NOZZLE SCHEDULE		
IDENTIFIER	CONNECTION	SIZE
A	VAPOR INLET	1-1/2" FNPT
B	VAPOR DISCHARGE	1-1/2" FNPT
C	PUMP DRAIN	3/8" FNPT
D	RECEIVER TANK DRAIN	1/2" FNPT

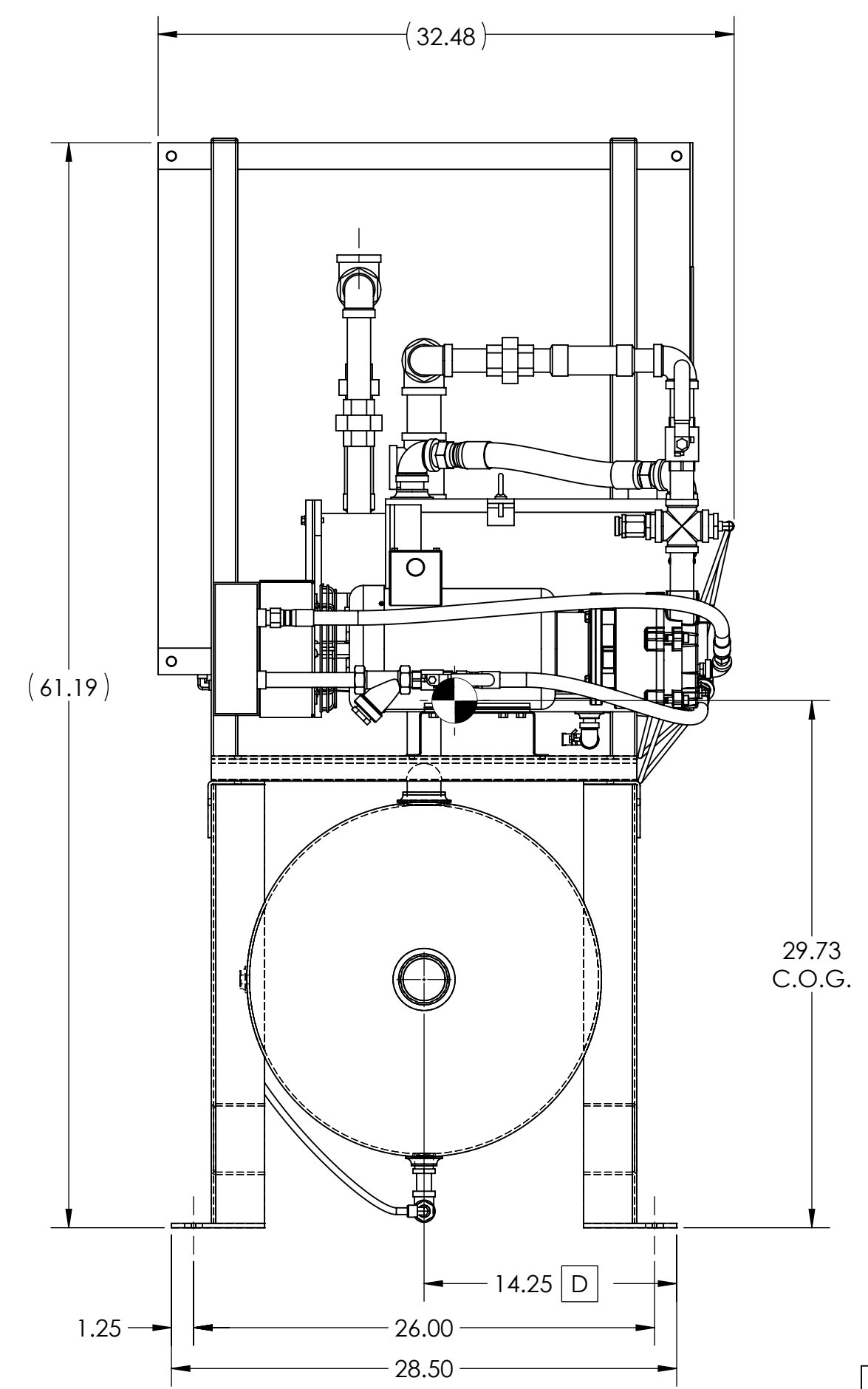
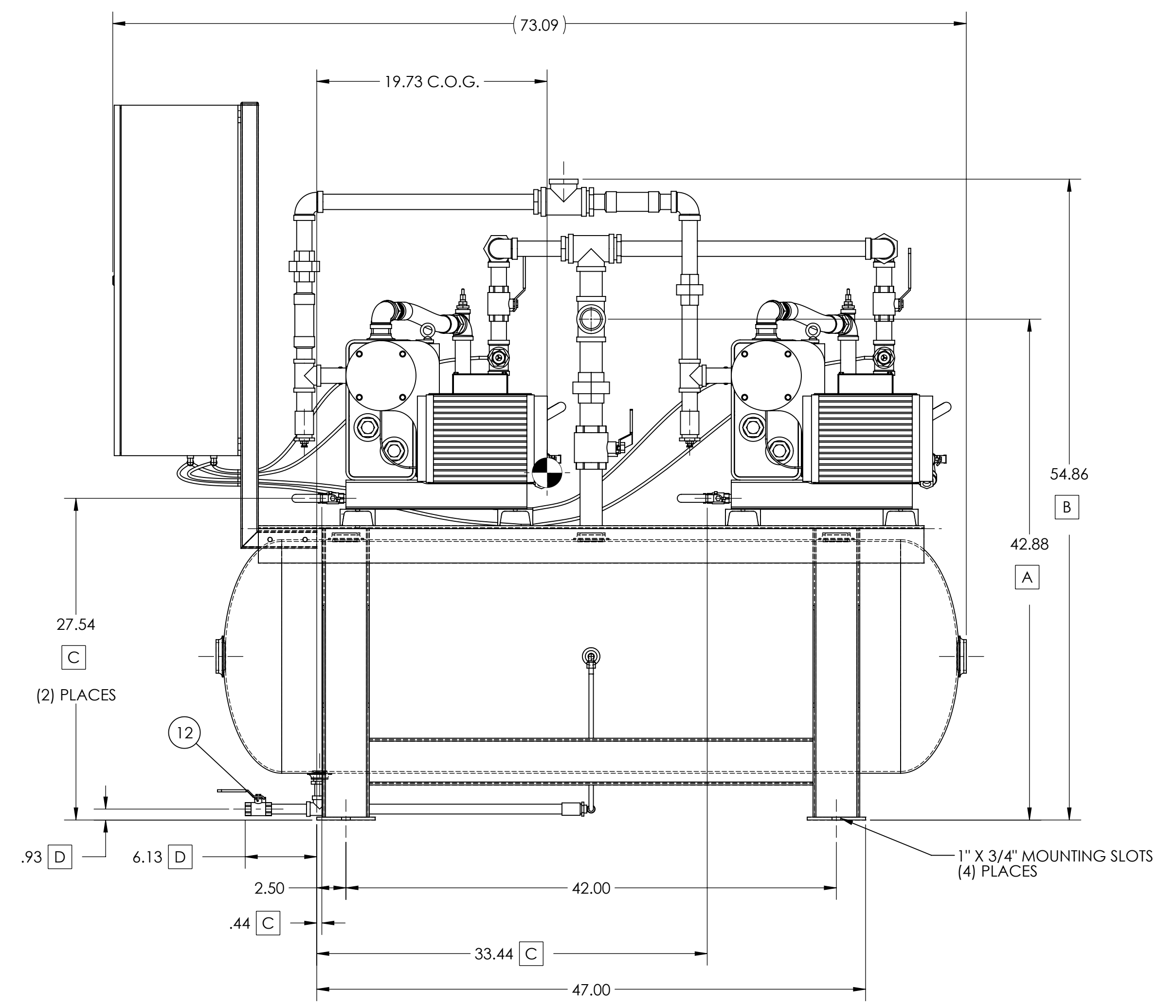

- NOTES:
 1) LOCATE VACUUM PUMP ON FLAT LEVEL SURFACE.
 2) PLUG ALL UNUSED PORTS WITH NPT PLUG.
 3) OIL CAPACITY (PER PUMP): 1.6 GALLONS P/N: 5220-3300-000
 4) REFERENCE WI-EN-039 FOR ALL HARDWARE TORQUE SPECIFICATIONS.

REVISIONS						
REV.	DESCRIPTION	DATE	DWG	ERP	APP	
A	REVISED FROM 200V TO 460V, SINGLE TO DUAL POWER FEED PANEL AND CIRC BRKR PER CUST REQ 4/19/18	5/9/2018	AWH	AWH	RHC	

TOLERANCES
 DECIMAL ± .50"
 FRACTIONAL ± 1/2"
 ANGULAR ± .50°
 UNLESS OTHERWISE SPECIFIED IN DRAWING

MODEL NO. VMX0036MA2-00-CS
 PART NO. 078284
 DESIGN BY: RHC DATE: 3/27/2018
 DRAWING BY: RHC DATE: 3/27/2018
 CHECKED BY: TJA DATE: 4/27/2018
 APPROVED BY: AWH DATE: 4/4/2018
 PROJECT ENG: RHC

DEKKER
 VACUUM TECHNOLOGIES, INC.

DESCRIPTION: VMX0036MA2-40-CS 460V TEFC
 DRAWING TYPE: SUBMITTAL
 DWG NO.: 2018157-D
 WEIGHT: 904.15 LB
 SCALE: 1:8
 SHEET NO.: 1 OF 1

CABINET LAYOUT

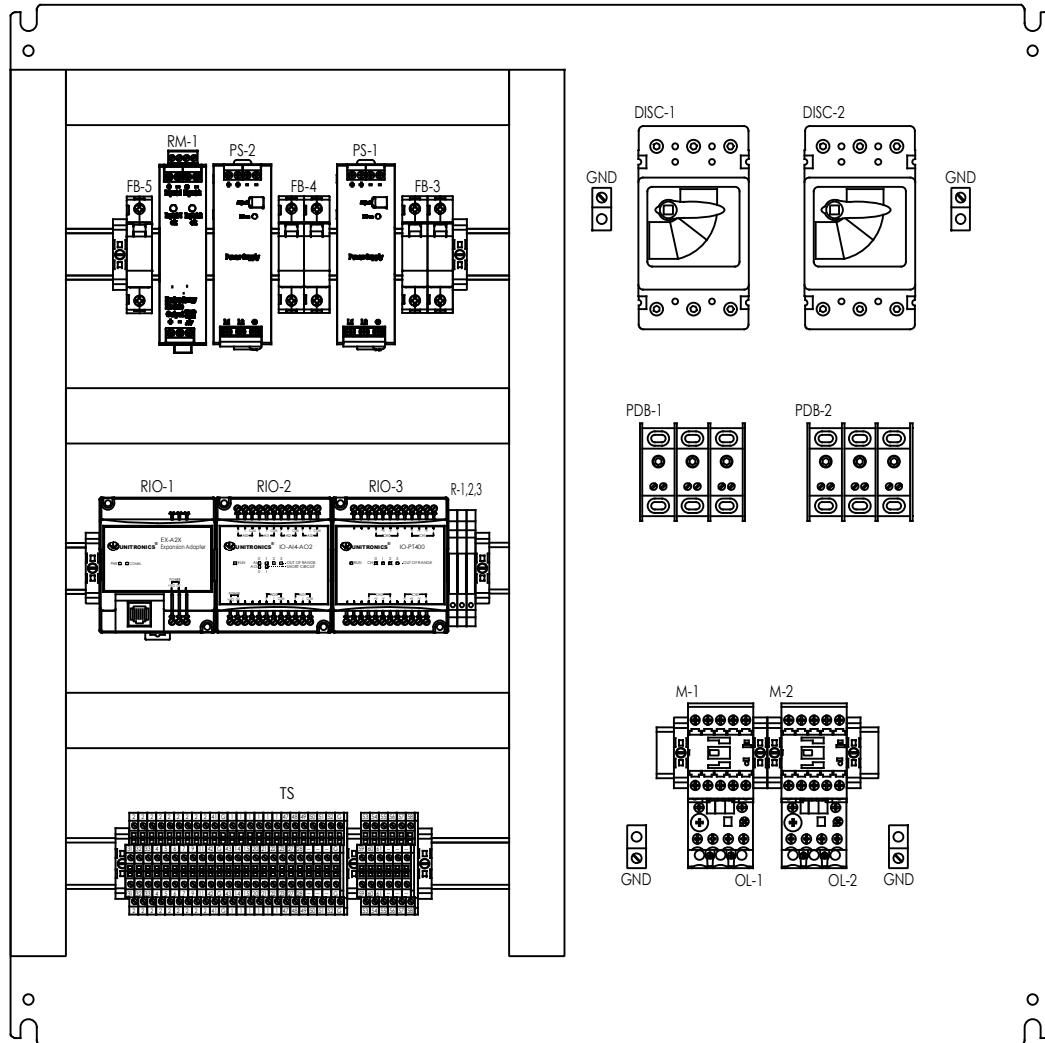
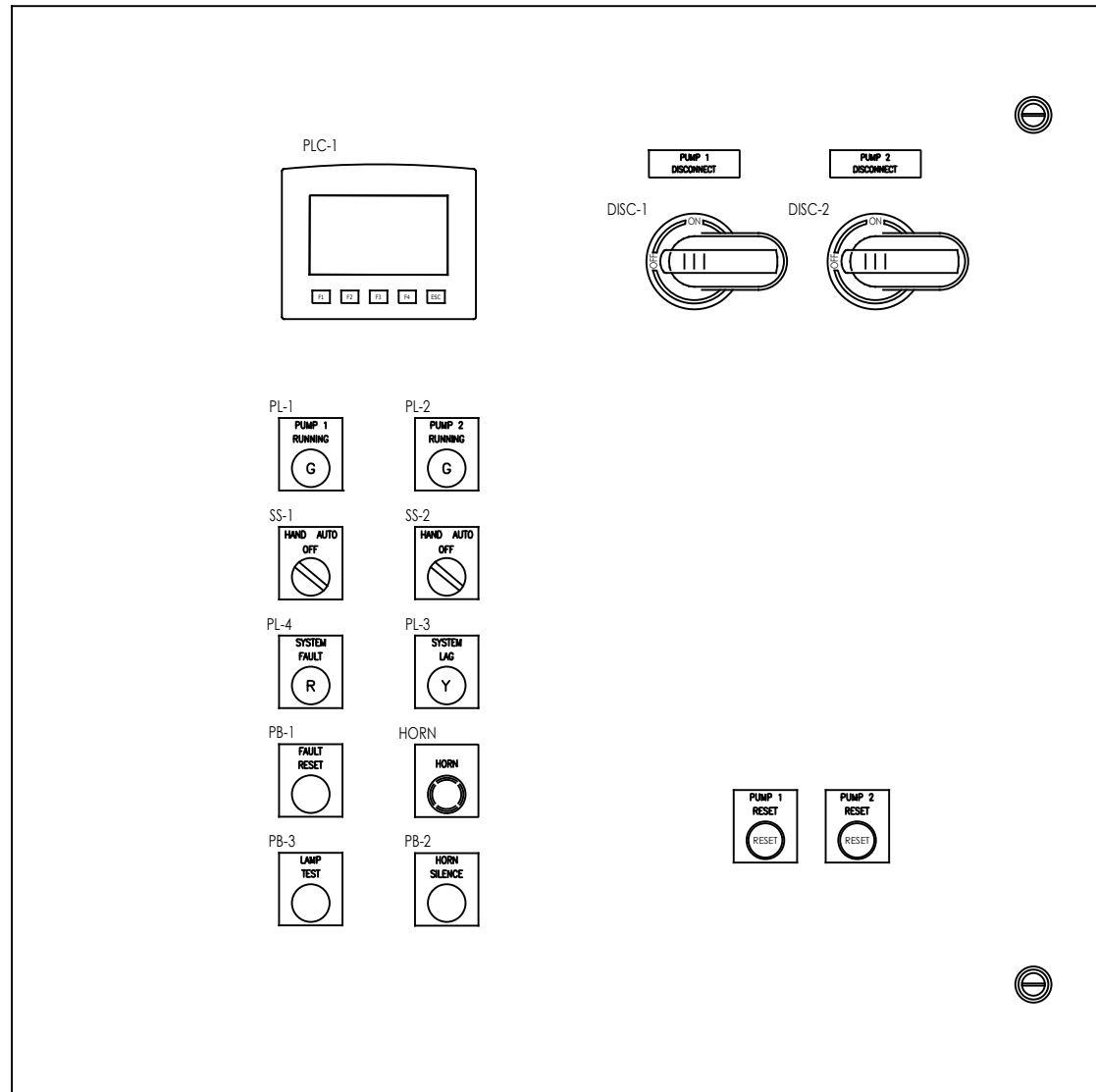

BILL OF MATERIALS				
ITEM	QTY	LABEL	DESCRIPTION	PART NUMBER
1	1	ENCL	ENCLOSURE N4/12 30" X 30" X 10"	2607-3030-100
2	1	ENCL	ENCLOSURE BACK PANEL 30" X 30"	2607-3030-000
3	2	PDB-1,2	POWER DISTRIBUTION BLOCK 3-POLE	2609-0214-003
4	6	PDB-1,2	POWER DISTRIBUTION BLOCK COVERS	2609-0214-103
5	2	DISC-1,2	CIRCUIT BREAKER, 15A, 460V	2670-0015-000
6	2	DISC-1,2	AUX CONTACT (1NO/1NC) EG FRAME BREAKER	2670-0001-001
7	2	DISC-1,2	DISCONNECT CIRCUIT BREAKER HANDLE	2670-0030-001
8	2	M-1,2	CONTACTOR AC IEC 7A 3PH C-H 24VDC	2598-0007-002
9	2	OL-1,2	OVERLOAD RLY FRAME B 2.4-4.0A C-H	2625-0004-003
10	2	FB-1,2	FUSE HDR FINGSF CL. CC 2POLE IND	2611-0002-002
11	4	FU-1,2,3,4	FUSE 4 AMP TIME DELAY CLASS CC	2610-0004-001
12	2	PS-1,2	POWER SUPPLY 24VDC 5A 380-480VAC	2621-0024-010
13	1	RM-1	REDUNDANCY MODULE, 24-48VDC, 20A	2621-0024-018
14	1	FB-3	FUSE HDR FINGERSF CL.MIDGET 1POLE	2611-0001-001
15	1	FU-5	FUSE 4 AMP FAST-ACTING MIDGET	2610-0004-002
16	1	PLC-1	UNITRONICS V430 22 DIG IN /12 RELAY OUT	2540-2400-018
17	1	CABLE	RIO CABLE 2.95m FOR EX-A2X REMOTE ADAPTR	2541-0024-004
18	1	RIO-1	UNITRONICS LOCAL I/O ADAPTER	2541-0024-002
19	1	RIO-2	UNITRONICS ANLG EXPANS MODULE 24VDC	2541-0024-001
20	1	RIO-3	UNITRONICS 4-CH RTD EXPANSION I/O	2541-0024-003
21	2	SS-1,2	SWITCH SELECTOR 3-POSITION NON ILL	2632-0030-006
22	3	PB-1,2,3	PUSH BUTTON BLACK	2630-0050-004
23	7	SS, PB	CONTACT BLOCK FOR SWITCH N.O.	2633-0020-002
24	3	R-1,2,3	RELAY 1 POLE 24V SPDT 6.2 mm 6A	2635-0010-000
25	2	PL-1,2	LIGHT GREEN PILOT 22MM 24V	2620-0022-017
26	1	PL-3	LIGHT YELLOW PILOT 22MM 24V	2620-0022-010
27	1	PL-4	LIGHT RED PILOT 22MM 24V	2620-0022-018
28	1	HORN	HORN PIEZO BLACK 24VDC/AC	2555-0050-001
29	1	TR-1	TRANS PRESS 0-15PSIA 0-10VDC	7120-0025-007
30	2	TR-2,3	TRANS PRESS 0-15PSIG 0-10VDC	7120-0025-008
31	3	TR-1,2,3	BUSHING BULK.75"UNC X .25"FNPT BRS	3002-7525-004
32	2	RESET	PUSH BUTTON OVERLOAD RELAY RESET	2630-0010-000
33	3	D-1,2,3	1A GENERAL DIODE 1N4000 SERIES	2555-4001-000
34	28	TS	ELEC.TERM BLOCK DOUBLE LEVEL 6.2MM	2604-2412-004
35	2	TS	ELEC.TERMINAL BLOCK GND 6.2 2-TIER	2604-2412-005
36	2	TS	ELEC.TERMINAL BLOCK END COVER	2606-2412-000
37	11	TS	ELEC.TERMINAL BLOCK END SECTION DIN	2606-2412-002
38	3.5	DIN RAIL	ELEC.TERM. BLK. DIN RAIL 7.5 X 35MM	2602-2410-000
39	7	WIRE DUCT	WIRING DUCT W/ COVER 1.50"X2.25" WH	9702-0150-225
40	4	GND	LUG, GROUNDING, 14-2 AWG	2552-1402-000
41	1	PLACARD	PLACARD SET FOR 2202-0657-290	2451-0657-290

SYSTEM APPROVAL

APPROVED BY:

DATE:

REVISIONS

REV	DESCRIPTION	DATE	DWG	ERP	APP
A	CHANGE VOLTAGE, ADD DUAL POWER CONNECTION	5/4/18	DLA	DLA	NTH

TOLERANCES

DECIMAL ± .0625"
 FRACTIONAL ± 1/16"
 ANGULAR ± 0° 30' 00"

UNLESS OTHERWISE SPECIFIED IN DRAWING

THIS PRINT IS PROPERTY OF DEKKER VACUUM TECHNOLOGIES, INC. AND MAY NOT BE GIVEN TO ANY OTHER CONCERN WITHOUT THE CONSENT OF DEKKER VACUUM TECHNOLOGIES, INC.

MODEL NUMBER:
VMX0036

PART NUMBER:
2202-0782-840

DESIGN BY: DLA DATE: 3/20/18

DRAWING BY: DLA DATE: 3/21/18

CHECKED BY: JMD DATE: 3/22/18

APPROVED BY: AWH DATE: 4/4/18

PROJECT ENG: AWH SERIAL NUMBER: -



DESCRIPTION:
MEDICAL CONTROL PANEL NFPA99
3HP DUPLEX VMAX 460V NEMA12

DRAWING TYPE: SUBMITTAL DWG NUMBER: 2018166-B

WEIGHT: 120 LBS SCALE: NONE SHEET NUMBER: 1 OF 4

INSTALL SOFTWARE: 2202-0691-950

POWER DISTRIBUTION

PANEL VOLTAGE: 480V / 3 PHASE / 60HZ
 PANEL FULL LOAD AMPS: 8.20 AMPS
 LARGEST MOTOR: 3 HP
 SCCR: 18KA RMS SYMMETRICAL AT 480V
 REFER TO APPLICABLE ELECTRICAL CODES FOR
 UPSTREAM PROTECTION AND INPUT WIRE SELECTION

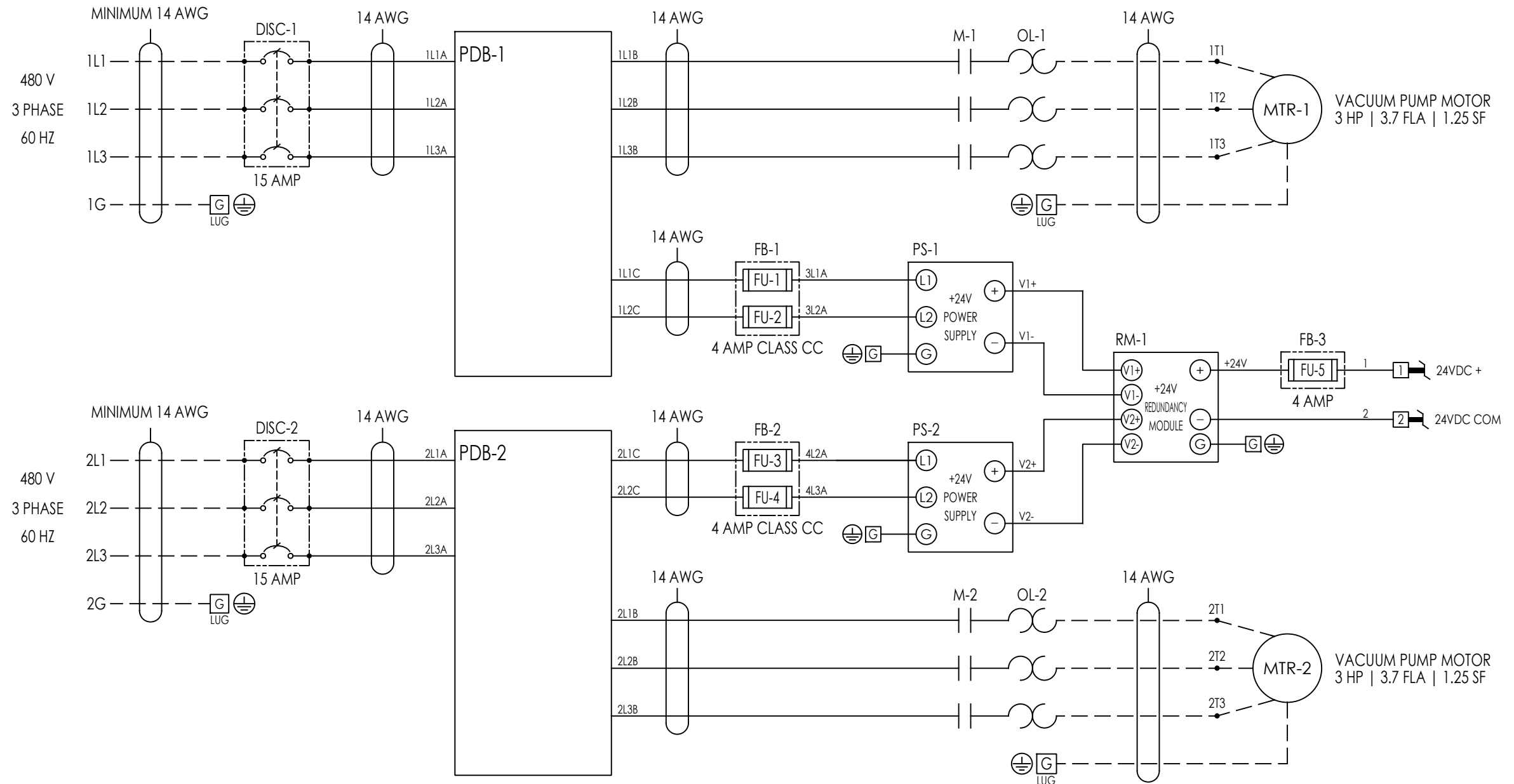

NOTES:

- INDICATES TERMINAL BLOCK
- INDICATES RELAY TERMINAL POINT
- USE COPPER WIRE ONLY
- REPLACE WITH LIKE FUSES ONLY
- UL/cUL LISTED CONTROL PANEL
- COMPLIANT TO NFPA 99 EDITION 2015
- TORQUE TERMINAL BLOCKS TO 5-7 LB-IN
- DENOTES EXTERNAL WIRING

REVISIONS

REV	DESCRIPTION	DATE	DWG	ERP	APP
A	CHANGE VOLTAGE, ADD DUAL POWER CONNECTION	5/4/18	DLA	DLA	NTH

TOLERANCES

DECIMAL	± .0625"
FRACTIONAL	± 1/16"
ANGULAR	± 0° 30' 00"

UNLESS OTHERWISE SPECIFIED IN DRAWING

THIS PRINT IS PROPERTY OF DEKKER VACUUM TECHNOLOGIES, INC. AND MAY NOT BE GIVEN TO ANY OTHER CONCERN WITHOUT THE CONSENT OF DEKKER VACUUM TECHNOLOGIES, INC.

MODEL NUMBER: VMX0036	
PART NUMBER: 2202-0782-840	
DESIGN BY: DLA	DATE: 3/20/18
DRAWING BY: DLA	DATE: 3/21/18
CHECKED BY: JMD	DATE: 3/22/18
APPROVED BY: AWH	DATE: 4/4/18
PROJECT ENG: AWH	SERIAL NUMBER: -



DESCRIPTION: MEDICAL CONTROL PANEL NFPA99 3HP DUPLEX VMAX 460V NEMA12	
DRAWING TYPE: SUBMITTAL	DWG NUMBER: 2018166-B
WEIGHT: 120 LBS	SCALE: NONE
SHEET NUMBER: 2 OF 4	

CONTROL - PLC

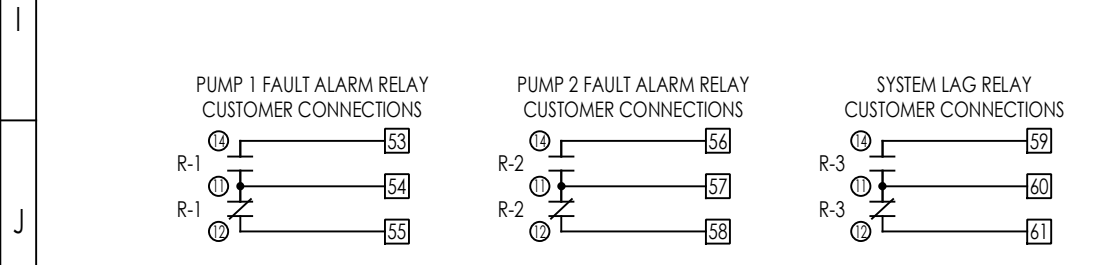
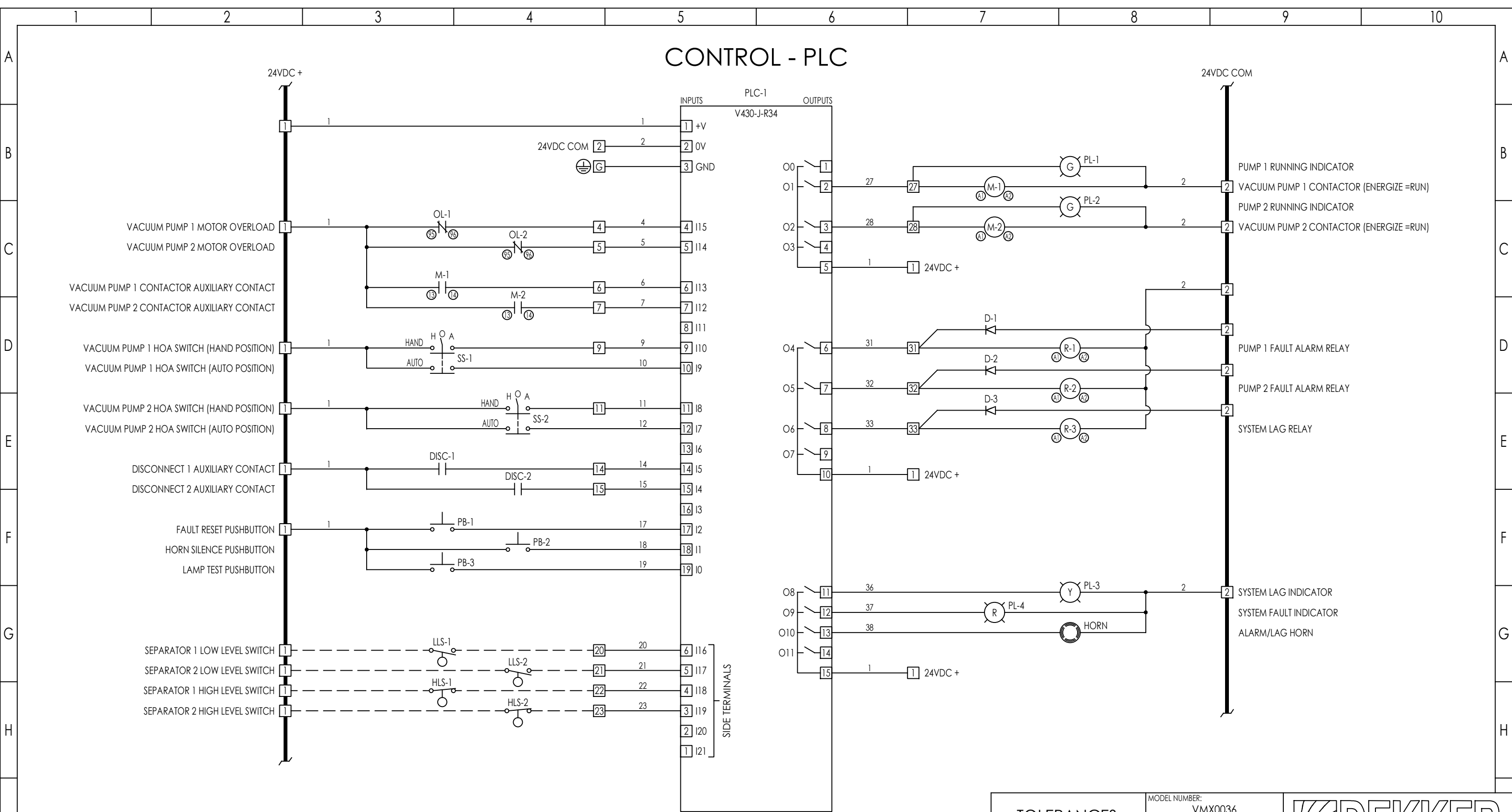

REVISIONS					
REV	DESCRIPTION	DATE	DWG	ERP	APP
A	CHANGE VOLTAGE, ADD DUAL POWER CONNECTION	5/4/18	DLA	DLA	NTH

TOLERANCES		MODEL NUMBER: VMX0036		
DECIMAL ± .0625"		PART NUMBER: 2202-0782-840		
FRACTIONAL ± 1/16"		DESIGN BY: DLA	DATE: 3/20/18	DESCRIPTION: MEDICAL CONTROL PANEL NFPA99 3HP DUPLEX VMAX 460V NEMA 12
ANGULAR ± 0° 30' 00"		DRAWING BY: DLA	DATE: 3/21/18	
UNLESS OTHERWISE SPECIFIED IN DRAWING		CHECKED BY: JMD	DATE: 3/22/18	
THIS PRINT IS PROPERTY OF DEKKER VACUUM TECHNOLOGIES, INC. AND MAY NOT BE GIVEN TO ANY OTHER CONCERN WITHOUT THE CONSENT OF DEKKER VACUUM TECHNOLOGIES, INC.		APPROVED BY: AWH	DATE: 4/4/18	DRAWING TYPE: SUBMITTAL
		PROJECT ENG: AWH	SERIAL NUMBER: -	DWG NUMBER: 2018166-B
		WEIGHT: 120 LBS	SCALE: NONE	SHEET NUMBER: 3 OF 4

CONTROL - ANALOG I/O MODULE

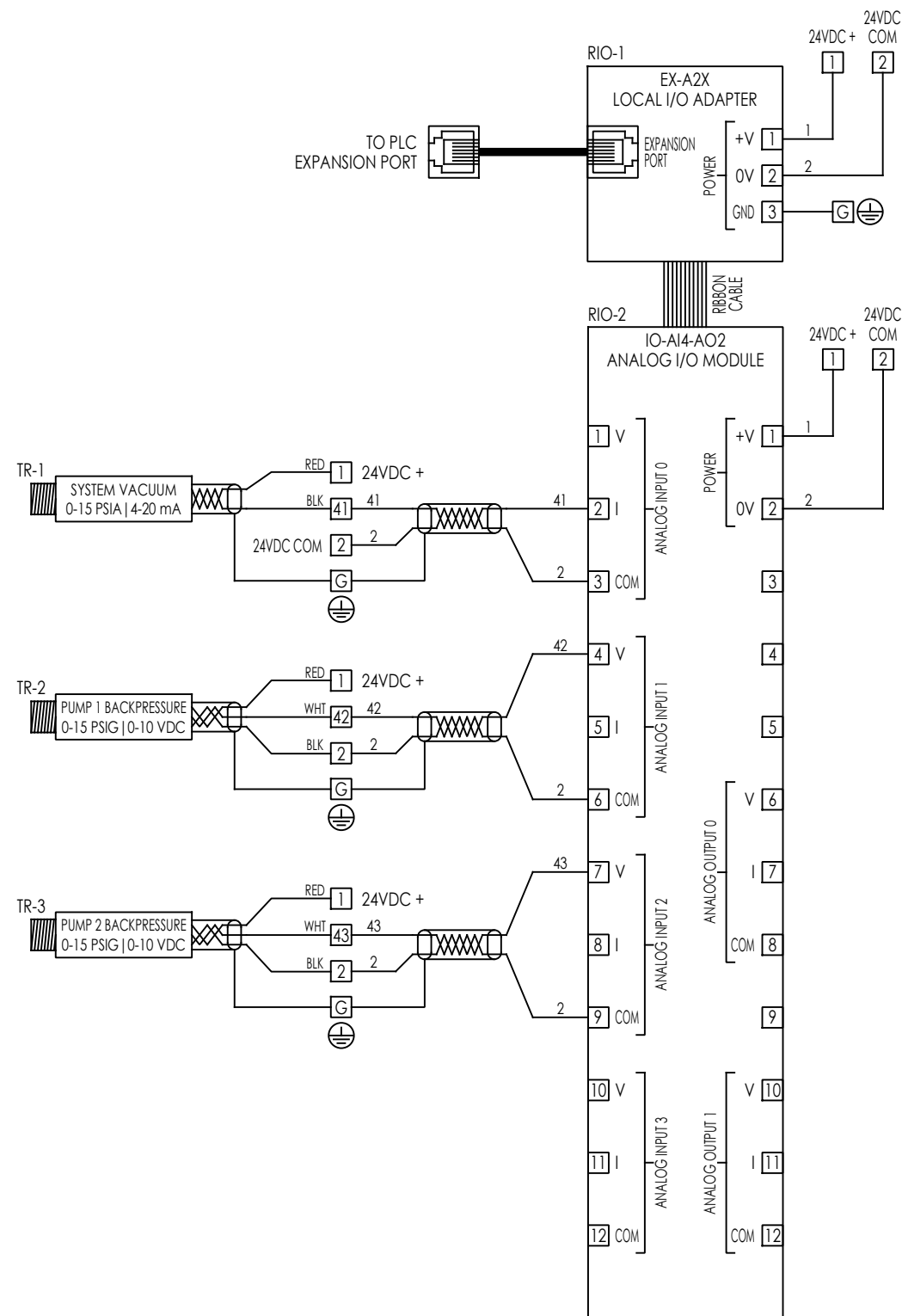

CONTROL - RTD MODULE

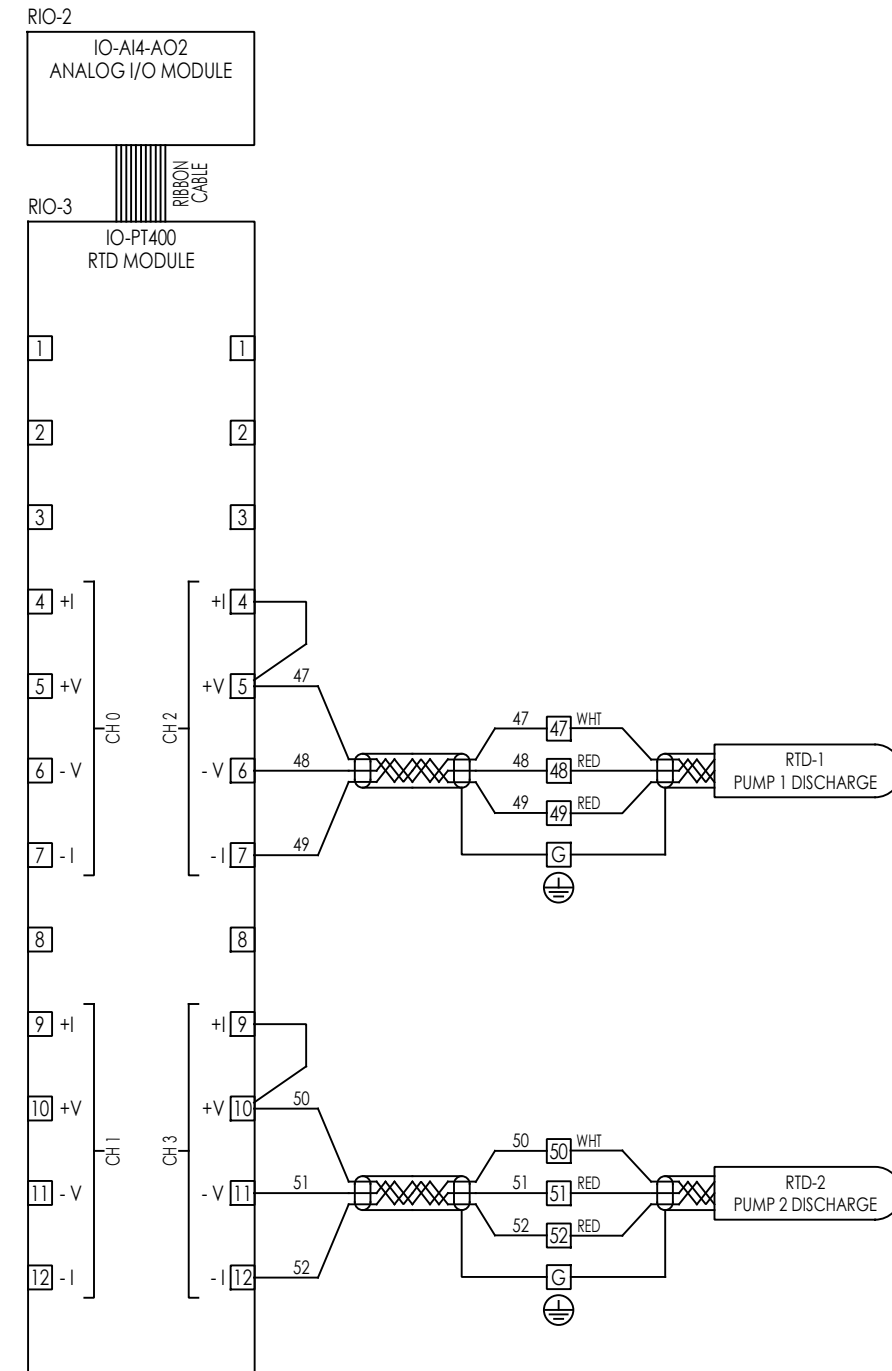

REVISIONS

REV	DESCRIPTION	DATE	DWG	ERP	APP
A	CHANGE VOLTAGE, ADD DUAL POWER CONNECTION	5/4/18	DLA	DLA	NTH

TOLERANCES

DECIMAL	± .0625"
FRACTIONAL	± 1/16"
ANGULAR	± 0° 30' 00"

UNLESS OTHERWISE SPECIFIED IN DRAWING

THIS PRINT IS PROPERTY OF DEKKER VACUUM TECHNOLOGIES, INC. AND MAY NOT BE GIVEN TO ANY OTHER CONCERN WITHOUT THE CONSENT OF DEKKER VACUUM TECHNOLOGIES, INC.

MODEL NUMBER:
VMX0036
PART NUMBER:
2202-0782-840

DESIGN BY:
DLA
DATE:
3/20/18

DRAWING BY:
DLA
DATE:
3/21/18

CHECKED BY:
JMD
DATE:
3/22/18

APPROVED BY:
AWH
DATE:
4/4/18

PROJECT ENG:
AWH
SERIAL NUMBER:
-



DESCRIPTION:
MEDICAL CONTROL PANEL NFPA99
3HP DUPLEX VMAX 460V NEMA12

DRAWING TYPE:
SUBMITTAL
DWG NUMBER:
2018166-B

WEIGHT:
120 LBS
SCALE:
NONE
SHEET NUMBER:
4 OF 4

Introducing the TITAN series high efficiency, single-stage liquid ring vacuum pump.

Why should you consider this vacuum pump for your application?

- ◆ Designed for heavy duty applications.
- ◆ 316 stainless steel impeller is standard.
- ◆ Features economical UL/CSA EPACT-compliant motor-mounted design.
- ◆ Manufactured to ISO 9001 standards.
- ◆ Low operating noise level.
- ◆ Features single face mechanical seal as standard.
- ◆ Virtually no maintenance is required.
- ◆ Compact design results in small footprint design.
- ◆ Capable of handling saturated gas mixtures.
- ◆ Capable of handling small amounts of liquids.
- ◆ Only one moving part.
- ◆ Can operate using various seal-fluids.



Performance characteristics
 Nominal capacity: 35CFM
 Motor: 60Hz/3HP/2.2kW
 50Hz/2HP/1.5kW
 Speed(RPM): 60Hz/3500
 50Hz/2900
 Max.vacuum: 29"Hg/25Torr
 Weight (including motor): 78Lbs/35kg
 Max. gas inlet temp: 212°F/100°C
 Max.noise level(at 3ft):70 dBA
Performance based on dry air, seal-water temperature 60°F and atmospheric pressure of 29.92"Hg.

DV0035B-MA

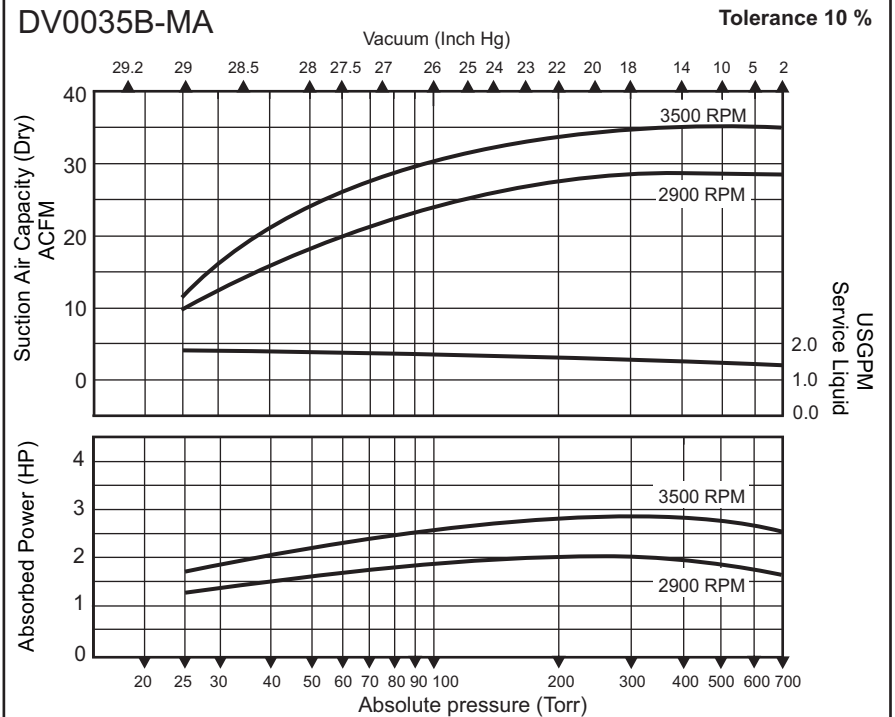

DV0035B-MA

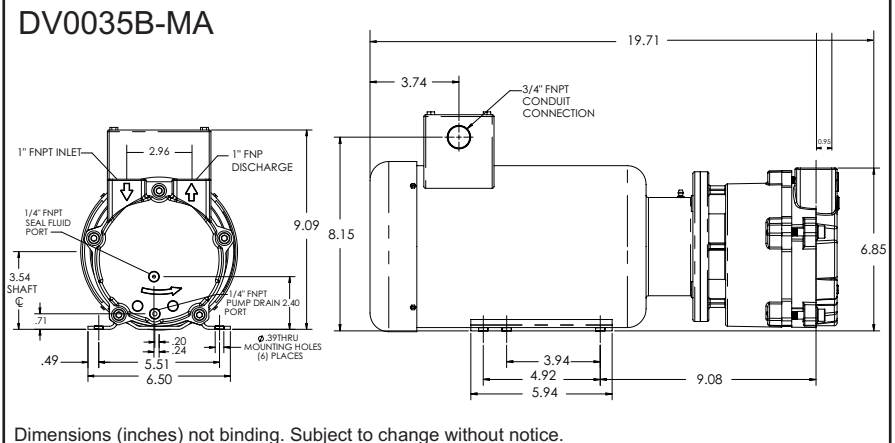

Materials of construction/Seal code				
Mat.code	1	2	3	4
Casing	NA	NA	cast iron	316 SS
Portplate	NA	NA	cast iron	316 SS
Impeller	NA	NA	316 SS	316 SS
Shaft	NA	NA	420 SS	316 SS
Seal code	NA	NA	A*	B*

A= standard mechanical seal with Viton elastomer
 B= standard mechanical seal with Teflon elastomer
 * = other seal materials available upon request.

VMX0036MA1
Maintenance Parts

Please verify Serial Number prior to order.
Filters and Accessories not included on all
standard systems.

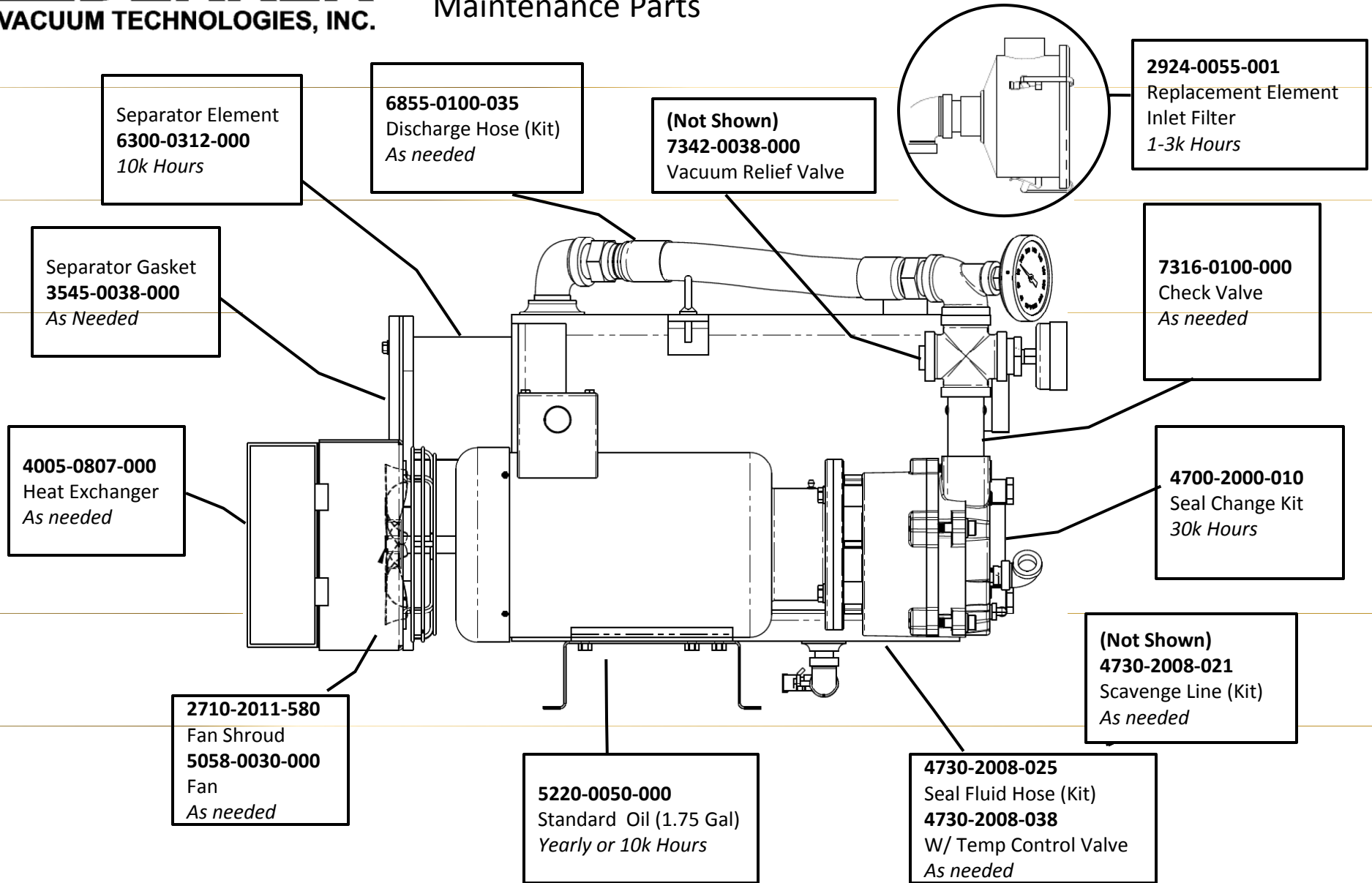



DEKKER
VACUUM TECHNOLOGIES, INC.

Installation
Operation
&
Maintenance
Manual



Oil-Sealed Liquid Ring Vacuum Pump Systems



OIL-SEALED LIQUID RING VACUUM PUMP SYSTEMS
TABLE OF CONTENTS

CUSTOMER SERVICE	5
CONTACT INFORMATION	5
ORDER INFORMATION	5
INTRODUCTION	6
SAFETY	6
THEORY OF OPERATION	7
STORAGE	8
INITIAL FREIGHT RECEIPT AND INSPECTION	8
INSTALLATION	8
OVERVIEW	8
UNPACKING	8
LIFTING	8
LOCATION	8
MOUNTING	9
VENTILATION	9
ELECTRICAL PREPARATION	10
PIPE CONNECTION AND SIZING	11
INLET PIPING	11
DISCHARGE PIPING	12
COOLING WATER PIPING	12
START-UP PROCEDURES	13
SHUT DOWN PROCEDURES	18
MAINTENANCE	18
PUMP BEARING LUBRICATION	18
MOTOR BEARING LUBRICATION (WHERE REQUIRED)	18
INLET FILTER (IF INSTALLED)	18
SEAL FLUID	18
OIL CHANGE PROCEDURE	18
VMX0203-VMX0553	19
VMX0063-VMX0153	20
VMX0036	20
STANDARD SYSTEM CAPACITIES	21

PRIMING THE PUMP	21
COMPLIMENTARY OIL ANALYSIS	21
OIL SOLENOID VALVE	22
SEAL FLUID STRAINER	22
SEPARATOR ELEMENT	22
SEPARATOR ELEMENT OIL RETURN LINE	22
SHAFT SEALS	22
MAINTENANCE SCHEDULE	23
<hr/>	
FIRST 8 HOURS OF OPERATION	23
DAILY	23
500 HOURS OF OPERATION	23
1000 HOURS OF OPERATION	23
10,000 HOURS OF OPERATION	23
30,000 HOURS OF OPERATION	23
DEVARNISHING	24
ACCESSORIES AND PROTECTIVE DEVICES (IF INCLUDED)	24
<hr/>	
ACCESSORIES	24
PROTECTIVE DEVICES	24
TROUBLESHOOTING	25
<hr/>	
START-STOP PROBLEMS	25
<i>UNIT WILL NOT START</i>	25
<i>UNIT SHUTS DOWN WHILE RUNNING</i>	25
VACUUM PROBLEMS	26
<i>UNIT OPERATES, BUT DOES NOT ACHIEVE DESIRED VACUUM LEVEL</i>	26
OVERHEATING PROBLEMS	26
<i>UNIT OVERHEATS OR OPERATES ABOVE 200°F</i>	26
<i>UNIT OVERHEAT ON START-UP IN LOW AMBIENT TEMPERATURES</i>	26
NOISE AND VIBRATION PROBLEMS	26
<i>THE SYSTEM IS MAKING AN ABNORMAL NOISE OR SOUND</i>	26
<i>SYSTEM IS VIBRATING EXCESSIVELY</i>	27
OIL PROBLEMS	27
<i>SYSTEM USES EXCESSIVE OIL OR PRODUCES AN OIL-MIST</i>	27
TROUBLESHOOTING QUICK REFERENCE GUIDE	28



**THIS INSTALLATION, OPERATION, AND
MAINTENANCE MANUAL MUST STAY WITH
EQUIPMENT.**

**PLEASE REGISTER YOUR EQUIPMENT
WARRANTY AND START-UP RECORD ONLINE
AT WWW.DEKKERVACUUM.COM**

CUSTOMER SERVICE

Contact information



935 SOUTH WOODLAND AVENUE, MICHIGAN CITY, IN 46360-5672

TEL.: 219-861-0661 – FAX: 219-861-0662 – TOLL-FREE: 888-925-5444

Bus. Hours: 7:30 a.m. – 4:30 p.m. CST

Website: www.DEKKERvacuum.com

E-mail: AfterSales_Support@DEKKERvacuum.com

Order Information

When calling for service, parts or system information always have the pump or system model number and serial number(s) ready. Refer to the bill of lading or the gold-colored system information plate attached to the system (see image below).

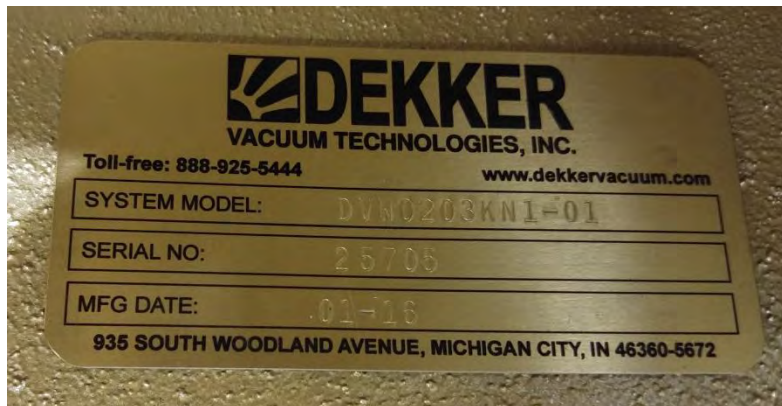

Gold-colored system information plate

Parts should be purchased from the nearest authorized DEKKER Vacuum Technologies, Inc. (hereafter referred to as DEKKER) representative (visit www.dekkervacuum.com to find a distributor near you via the [Distributor Locator](#)) or from the vacuum pump system supplier. If, for any reason parts, cannot be obtained in this manner, contact the factory directly.

INTRODUCTION

The Vmax oil-sealed liquid ring vacuum pump system has been designed to give you safe, reliable, trouble-free service provided some of the basic maintenance guidelines as set out in this manual are followed. Compared to other vacuum pump systems, the Vmax oil-sealed liquid ring vacuum pump system offers the advantages of no metal-to-metal contact between the impeller and casing. Grease lubricated bearings are mounted external to the pumping chamber, isolated by mechanical shaft seals. This means that the pump requires no internal lubrication. However, a vacuum pump is a rotating piece of equipment and operators must exercise good judgment and follow proper safety procedures to avoid damage to the equipment or personal injury. Please review and follow all instructions in this manual before attempting to install, start or operate equipment.

SAFETY

All vacuum pumps, systems and/or compressors (hereafter referred to as the Product) offered by DEKKER have been designed and manufactured for safe operation. However, the responsibility for safe operation rests with those who use and maintain these products. The safety department where the product is installed should establish a safety program based on OSHA, federal, state, and local codes. It is important that due consideration be given to hazards which arise from the presence of electrical power, hot liquids, harmful gases, and rotating equipment. Proper installation and care of protective devices is essential to safe system operation. These safety procedures are to be used in conjunction with the instructions contained in this manual.



**WARNING: DO NOT PUMP OXYGEN or oxygen rich mixtures with these pumps -
EXPLOSION HAZARDS!**

THEORY OF OPERATION

The DEKKER Vmax oil-sealed liquid ring vacuum pump system includes our high efficiency liquid ring vacuum pump. The impeller assembly is the only moving part which rotates freely in the casing without metal-to-metal contact which means no additional lubrication is required. The function of the sealing liquid is to create a liquid piston action used to produce vacuum and to remove the heat of compression. The seal fluid, hereafter referred to as oil, in the system circulates in a closed loop passing through an air- or water-cooled heat exchanger that removes the heat of compression. The discharge separator/reservoir holds the seal fluid and incorporates the DEKKER DX-5 or DX-7 patented high-efficiency separator arrangement to separate the seal fluid from the air or gases discharged by the pump. See "Piping and Instrument Diagram" of the Vmax oil-sealed liquid ring vacuum pump system below.

Piping and Instrument Diagram

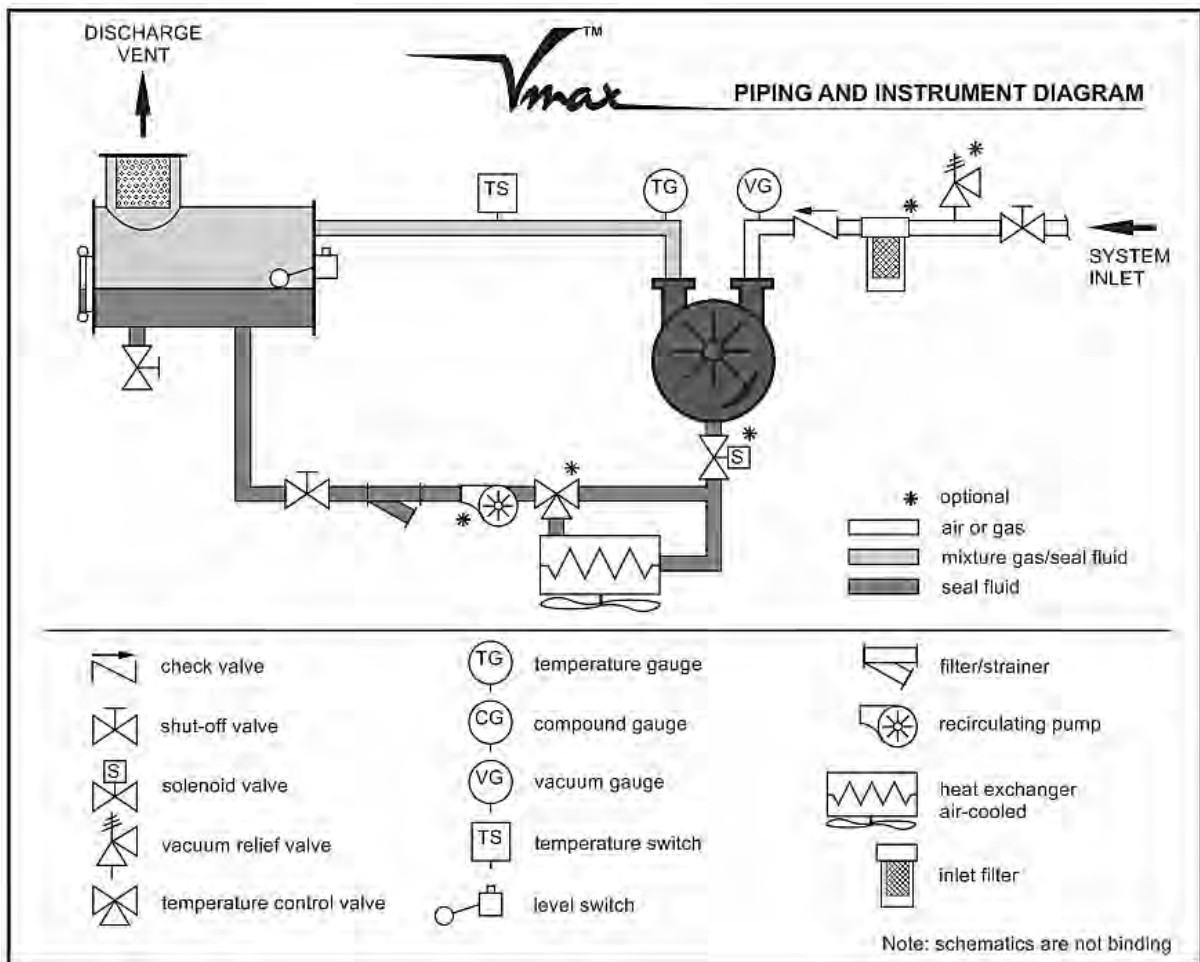

STORAGE

Keep the system in a cool dry environment and close the seal fluid isolation valve as shown on [page 17](#). Plug all open ports to keep out dirt and foreign objects. Every 2 weeks rotate the impeller by rotating the shaft by hand 2 ¼ turns.

INITIAL FREIGHT RECEIPT AND INSPECTION

Before a system ships from DEKKER, it is thoroughly tested, and will not be released unless it passes our Quality Control standards. All pumps are thoroughly inspected and are not released unless they pass our Quality Control standards. Once the product is received and signed for in Good Condition, DEKKER cannot be held accountable for undiscovered, unclaimed damage that is a result of freight transit. It is the responsibility of the receiver to thoroughly inspect and test the product for functionality upon delivery. The customer should take photos of the product as it arrives and send to DEKKER and the freight carrier if there are any issues. The party who selected the shipper is responsible for filing the freight claim. Failure to report these issues within the freight carriers' undiscovered damage window can result in non-acceptance of freight claims. DEKKER does keep photos of all systems, as shipped, to assist in freight claims. Report any damage immediately to AfterSales_Support@DEKKERvacuum.com.

Key items to inspect:

- Is the product received as requested? Are all parts, accessories, and components delivered?
- Was the skid or crating received in good condition? Check for cosmetic damage.
- Check wiring inside of control panel. Are all wires should be terminated and connections tight? (If applicable)
- Check control panel components. Are they tight on DIN rail and/or other mounts/fasteners?
- Are there any leaks or puddles around the pump? Specify hose, piping or housing leak.

System must be given an initial startup test as soon as possible after delivery. This is to ensure that the motor has not shifted out of alignment during transit as well as to verify that electrical components are functioning without fault – Variable Frequency Drive (VFD), Programmable Logic Controllers (PLC), panel cooling fans, transducers.

INSTALLATION

Overview

The design of the piping system, foundation layout, and plant location are the responsibility of the purchaser. DEKKER Vacuum Technologies, Inc. and its representatives may offer advice, but cannot assume responsibility for operation and installation design.

Please consult the factory or a specialist skilled in the design of plant layout, system piping design, and foundation design. The installer should carefully read this manual before installing the equipment. DEKKER or your authorized dealer can provide start up assistance in most instances for a fee. Contact DEKKER for hourly/daily service rates.

Unpacking

Upon receipt of pump or system, immediately inspect for signs of damage. Carefully remove packing or crating from around pump or system. Be sure to keep equipment in upright position.

Lifting

Lift the equipment carefully and with weight evenly distributed. DEKKER is not responsible for equipment that has been damaged through mishandling or dropping.

Location

Install the unit in a well ventilated and dust free area. The pump or system should be a minimum distance of 3 feet from surrounding walls to allow for checking fluid level, temperatures, pressures and general servicing.

Mounting

The pump or system must be installed on a level surface in the horizontal position. The foundation must be designed to support the total unit weight, without any settlement or crushing, be rigid and substantial enough to absorb any equipment vibration, maintain true alignment with any drive mechanism, and must permanently support the system baseplate at all points. The vacuum system must be leveled and secured with anchor bolts. Anchor bolts must be of adequate size to withstand the mechanical stresses exerted on it.

Systems 50 HP and larger should also be grouted into position per local codes. The foundation should be constructed to allow for $\frac{3}{4}$ to 1- $\frac{1}{2}$ inch of grout. The baseplate is set on shims and the grout is poured between the foundation and the baseplate. To have the required body to support the baseplate, grout should be at least $\frac{3}{4}$ inch thick.

The number and location of shims will be determined by the design of the baseplate. Firm support should be provided at points where weight will be concentrated and at the anchor bolt locations. Use enough, and large enough, shims to provide rigid support. Baseplates are usually designed with openings to allow pouring grout. When the baseplate has been shimmed, leveled, and the anchor bolts have been snugly tightened, a dam is constructed around the foundation to contain the grout. The dam level should be at least $\frac{1}{2}$ inch above the top surface of the shims. Grout should be poured inside and around the outside of the baseplate and leveled. Allow the grout to dry for a minimum of 48 hours before tightening the anchor bolts.

Please note that the pump/motor coupling and V-belt units will need to be realigned prior to start-up, with the exception of monoblock units.

Ventilation

Locate the unit in an area with sufficient airflow and accessibility. To prevent excessive ambient temperature rise, it is imperative to provide adequate ventilation. Cooling is an important aspect of reliable equipment operation and it is therefore important to install the unit in a reasonably cool area where the temperature does not exceed 104°F (40°C). For higher ambient temperatures contact the factory.

Typical system operating temperature is between 140° - 185°F. Minimum oil temperature should not be below 45°F.

Electrical Preparation

Wire Size Chart (AWG) by Vmax Horsepower

Recommended Wire Size and Disconnect Size for Vmax Systems

Vmax			FLC NEC Tables			Volt.	Copper AWG (kcmil)			Recommended Conduit Size in Inches			Recommended Fused Disconnect (Amps)			Recommended Class J Fuse		
System		Serv.	200V	230V	460V		200V	230V	460V	200V	230V	460V	200V	230V	460V	200V	230V	460V
Model No.	HP	Fact.				Tol.												
VMX0023MAI	1.5	1.15	6.9	6	3	±10%	14	14	14	1/2"	15	15	15	12	10.5	5.25		
VMX0023KA1	1.5	1.15	6.9	6	3	±10%	14	14	14		15	15	15	12	10.5	5.25		
VMX0036MAI	3	1	11	9.6	3.7	±10%	14	14	14		20	20	15	19.2	16.8	8.4		
VMX0036KA1	3	1.15	11	9.6	4.8	±10%	14	14	14		20	20	15	19.2	16.8	8.4		
VMX0063MAI	5	1.15	17.5	15.2	7.6	±10%	12	12	14		40	30	15	30.6	26.6	13.3		
VMX0063KA1	5	1.4	17.5	15.2	7.6	±10%	12	12	14		40	30	15	30.6	26.6	13.3		
VMX0083MAI	5	1.15	17.5	15.2	7.6	±10%	12	12	14		40	30	15	30.6	26.6	13.3		
VMX0083KA1	5	1.4	17.5	15.2	7.6	±10%	12	12	14		40	30	15	30.6	26.6	13.3		
VMX0103MAI	7.5	1	25.3	22	11	±10%	10	10	14		50	40	20	44.2	38.5	19.2		
VMX0103KA1	7.5	1.3	25.3	22	11	±10%	10	10	14		50	40	20	44.2	38.5	19.2		
VMX0153MAI	10	1	32.2	28	14	±10%	8	10	14		60	50	30	56.3	49	24.5		
VMX0153KA1	10	1.28	32.2	28	14	±10%	8	10	14		60	50	30	56.3	49	24.5		
VMX0203KA1	15	1.3	48.3	42	21	±10%	6	6	10	3/4"	3/4"	1/2"	90	80	40	84.5	73.5	36.7
VMX0303KA1	20	1.25	62.1	54	27	±10%	4	6	10	1"	3/4"	1/2"	110	100	50	109	94.5	47.2
VMX0303KA1-20	20XP	1.15	62.1	54	27	±10%	4	6	10	1"	3/4"	1/2"	110	100	50	109	94.5	47.2
VMX0453KA1	25	1.3	78.2	68	34	±10%	3	4	8	1"	1"	1/2"	140	120	60	137	119	59.5
VMX0453KA1-20	25XP	1.15	78.2	68	34	±10%	3	4	8	1"	1"	1/2"	140	120	60	137	119	59.5
VMX0553KA1	40	1.3	120	104	52	±10%	0	1	6	1.25	1.25	3/4"	220	190	100	210	182	91
VMX0553KA1-20	40XP	1.15	120	104	52	±10%	0	1	6	1.25	1.25	3/4"	220	190	100	210	182	91
VMX0753KA1	50	1.28	150	130	65	±10%	0	0	4	1.5	1.5	1"	270	230	115	262	227	114
VMX1003KA1	60	1.15	177	154	77	±10%	0	0	3	2	1.5	1"	320	270	140	310	269	135
VMX1103KA1	75	1.15	221	192	96	±10%	300	0	1	2	2	1.25	390	340	180	387	336	168
VMX1203KA1	100	1.15	285	248	124	±10%	500	350	0	2.5	2.5	1.25	510	440	230	499	434	217

- NOTES:**
- Based on no more than three single insulated conductors rated 0-2000 volts.
 - Conduit sizes shown at 9.6%. Fill does include ground conductor if required (over 60 amperes).
 - Wire sizes are based on NEC Table 310.15.b.16 @ 75°C rated conductors.
 - Approved trade size conduit or metal tubing.
 - Above information is general information. Per NEC tables please confirm motor FLA does not exceed FLC.
 - If fuse is not a standard size, choose the next higher standard size.
 - If disconnect is not a standard size, choose the next higher standard size.

Note: Fuse and disconnect sizes are for vacuum pump only. For main disconnect and fuse sizes for systems with a circulation pump and fan, multiply the FLC of the vacuum pump motor by 175% then add the FLC for the circulation pump and fan to get the fuse size. Disconnect must be sized to fit fuse.

All system wiring is performed at the factory if a control panel is supplied and installed on the skid. Check area classification to ensure all electrical enclosures comply with code. Required customer wiring is minimal, but should be done by a qualified electrician in compliance with OSHA, National Electric Code and any other applicable local electrical code concerning switches, fused disconnects, etc. DEKKER includes a wiring diagram in the control panel for use by the installer. DEKKER recommends a main disconnect switch be fitted between the vacuum system and the incoming power.

After the electrical wiring connections are completed, check the incoming voltage to make sure the incoming voltage is the same as the vacuum system voltage. Line voltage should be within the voltage tolerance as specified on the motor or to local code. Check the system for proper motor rotation. The direction of rotation is marked by an arrow on the motor or pump housing. Jog the motor by pressing the ON button and then the OFF button. If the rotation is incorrect, switch any two of the three main power leads (three phase power) on the contactor inside the control panel. Failure to do so could result in serious equipment damage.



WARNING: Install, ground, and maintain equipment in accordance with the National Electrical Code and all applicable federal, state and local codes.

WARNING: For NFPA 99 hospital and generator applications, please shut down the vacuum pumps prior to generator testing. The rapid stop and restart may cause damage to the pump and/or motor and cause damage to electrical panel and related components.

Pipe Connection and Sizing

Before installation, remove all protective inserts on the pump suction and discharge. Piping connected to the system must be installed without imposing any strain on the system components. Improperly installed piping can result in misalignment, general operating problems and pump failure. Use flexible connectors where necessary. Piping must be cleaned of debris before installation.

DEKKER recommends CPVC piping as discharge temps may exceed +170°F. CPVC is rated for 200°F max, and PVC is only rated for 140°F max. Schedule 40 PVC piping is generally acceptable for the inlet connections.

Inlet Piping

Note: Install a temporary screen at the pump inlet flange at first start-up to protect the unit against carryover of pipe debris and welding slag. The screen must be removed after the initial run-in period.

Inlet piping should be at least the size of the pump inlet. Install the system as close as possible to the process to minimize losses due to the length of the suction line. If the system has to be installed further away from the process, be sure the inlet piping is properly sized to minimize the overall line pressure drop. For more information consult your authorized dealer or contact the factory.

Pump systems operating in parallel on a common manifold must each have a manual or automatic shut-off valve and a suitable check valve installed in the suction line close to the pump suction flange. This allows each individual system to be isolated when it is not in operation. The line size of the manifold should be a minimum equal to the sum of the individual system pipe areas.

Systems are supplied with an inlet check valve as standard. This valve is installed close to the pump suction flange to prevent back flow of process gas and seal fluid when the pump is stopped.

If the inlet gas pumped contains dust or foreign particles, a suitable 5 micron (or finer) inlet filter should be installed at the inlet port. For more information consult your authorized dealer or the factory.

If the possibility exists that the pump inlet can become closed during operation it will be essential to install some type of vacuum relief valve (anti-cavitation valve) so that air can enter the pump inlet. Never run a pump with a closed suction. This causes hydraulic knock / cavitation and can damage the pump.

Discharge Piping

Discharge piping must be at least the size of the separator discharge. Do not discharge the exhaust gases from the pump system into the area where the system is installed. Vapors pulled over from the process could be hazardous. Install an exhaust line of at least the same diameter as the discharge connection on top of the separator reservoir leading outside. See the “Discharge Piping Diagram” as shown below.

For vacuum pump systems operating in parallel on a common discharge, DEKKER recommends the installation of a suitable check valve close to the separator discharge flange of each unit. Discharge check valves should be a low differential pressure type with positive shutoff. This will prevent discharge gasses from back flowing to other systems. When discharging more than one pump in a common discharge line and/or over a long distance, oversize pipe accordingly.

Discharge Piping Diagram

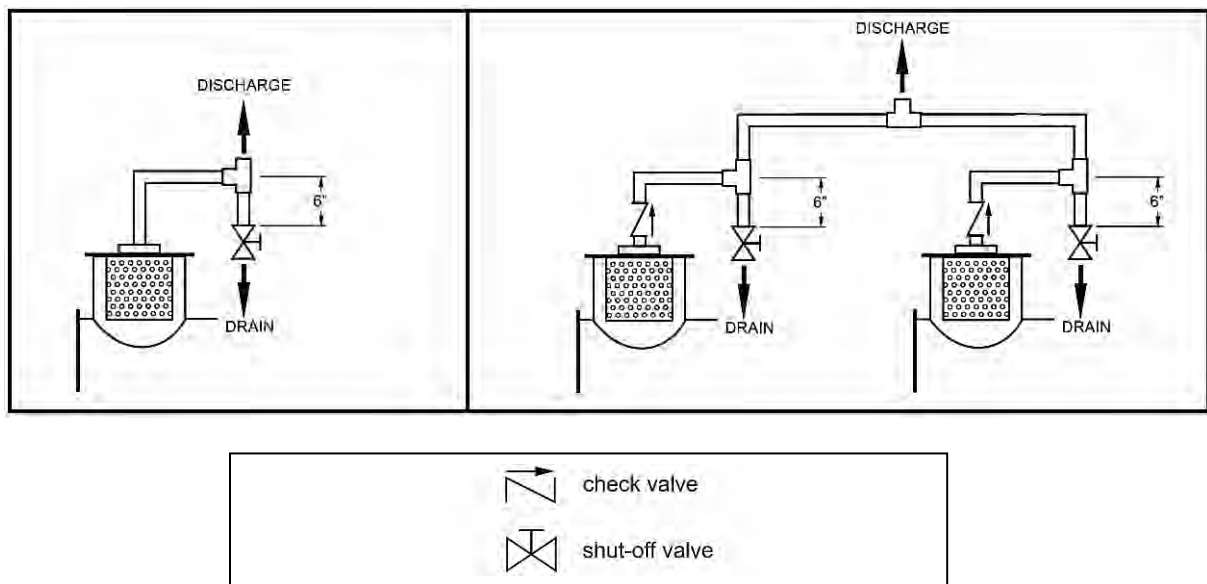

Cooling Water Piping

Water-cooled systems require an adequate supply of cooling water at a maximum of 85°F and a minimum supply pressure of 20 psig. If the cooling water temperature is higher or available pressure lower, contact your authorized dealer or the factory.

The cooling water outlet connection of the heat exchanger may be fitted with an optional automatic temperature control valve, which regulates the cooling water flow rate depending on pump operating temperature. The valve is preset at the factory. To raise the system operating temperature, turn the valve-adjusting screw counter-clockwise. To lower operating temperature, turn clockwise. Normal system operating temperature is between 140°-185°F. Minimum oil temperature should not be below 45°F. The valve will only open when the system operating temperature is reached.

START-UP PROCEDURES

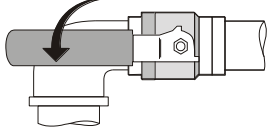
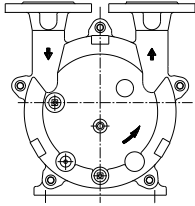
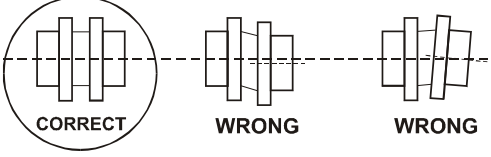
1	Ensure all shipping plugs and/or paper covers are removed from system and tagging information is followed for successful startup.	
2	Ensure seal fluid isolation valve is open (NOTE: There may be more than one valve). This valve is located below the separator and/or near the y-strainer.	 <p style="text-align: center;">Seal Fluid Isolation Valve</p>
3	Jog the motor briefly and check direction of rotation. The direction of rotation is marked by an arrow on the motor or pump housing. If direction is incorrect, switch any two of the three leads at the power connection (three phase only). The correct direction of rotation is clockwise facing the pump from the drive end and counter-clockwise if viewed from the non-drive end.	
4A	Check drive coupling alignment. Angular and parallel alignment should be within the following chart allowances (<u>see next page, item 4A.1</u>). Consult the factory for specific system size alignment. Mono-block units do not require any field adjustment (motors are C-face mounted).	

4A.1

Alignment Chart

Pump Model	Sleeve Size	Maximum RPM	Parallel Misalignment	Angular Misalignment	"B"
--	3	9200	0.010	0.035	1.188
--	4	7600	0.010	0.043	1.500
DV0036	5	7600	0.015	0.056	1.938
DV0060-80	6	6000	0.015	0.070	2.375
DV0100-0150	7	5250	0.020	0.081	2.563
DV0200-0300	8	4500	0.020	0.094	2.938
DV0450	9	3750	0.025	0.109	3.500
DV0550	10	3600	0.025	0.128	4.063
--	11	3600	0.032	0.151	4.875
--	12	2800	0.032	0.175	5.688
--	13	2400	0.040	0.195	6.625
--	14	2200	0.045	0.242	7.750
--	16	1500	0.062	0.330	10.250

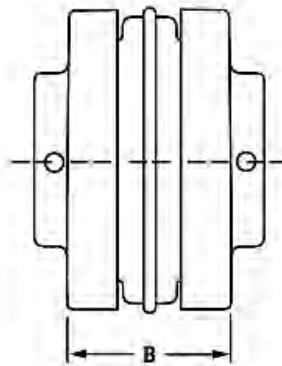

Figure 1
B Dimension

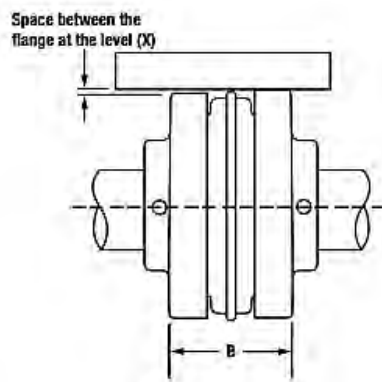

Figure 2
Parallel Measurement

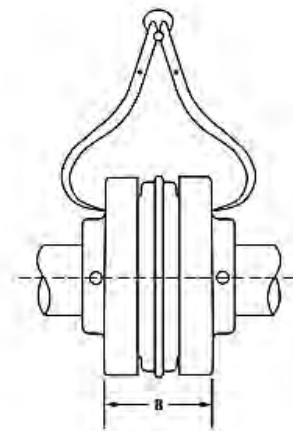

Figure 3
Angular Measurement

<p>4B</p>	<p>For units utilizing V-belt drives, make sure the sheaves are properly installed and aligned before attempting to tension the drive. The V-belts should be placed over the sheaves and in the grooves without forcing them over the sides of the grooves. The tensioning steps below can be used for all types of V-belts, all cross sections and number of belts and all types of construction.</p> <p>Avoid excessive heat (140°F and higher); belt life will be shortened. Never switch or mix belts from one groove to another on the sheaves. Do not use belt dressing. Sheaves should remain free of oil and grease. When replacing belts install an identical set.</p> <p>For more specific V-belt tensioning guidelines consult factory.</p> <p>Sheave alignment should be checked by placing a straight edge or tight cord across the sheave faces so that it touches all four points of contact. Ordinarily, a misalignment of more than one-half of one degree (one eighth inch in one foot) will adversely affect belt life. Improper sheave alignment produces uneven wear on one side of the belt, causes the belt to roll over in the sheaves or throws the entire load on one side of the belt, stretching or breaking the cords on that side.</p> <p><u>Tensioning a Drive - General Rules of Tensioning</u></p> <ol style="list-style-type: none"> 1. Ideal tension is the lowest tension at which the belt will not slip under peak load conditions. 2. Check tension frequently during the first 24-48 hours of run-in operation. 3. Over tensioning shortens belt and bearing life. 4. Keep belts free from foreign material which may cause slip. 5. Make V-Drive inspection on a periodic basis. Tension belt when slipping. Never apply belt dressing as this will damage the belt and cause early failure. 6. If the unit is idle for an extended period of time, the tension on the belts should be removed. 	<p><u>Simple Tensioning Procedure</u></p> <ol style="list-style-type: none"> 1. Measure the span length. 2. At the center of the span apply a force (perpendicular to the span) large enough to deflect the belt 1/64", for every inch of span length. For example, one deflection of a 100 inch span would be 100/64 or 1-9/16 inches. 3. Compare the force you have applied with the values given in <u>Table 4B.1 on the next page</u>. If the force is between the values for normal tension, and 1-1/2 times normal tension, the drive tension should be satisfactory. A force below the value for normal tension indicates an under tensioned drive. If the force exceeds the value for 1-1/2 times normal tension, the drive is tighter than it needs to be. 4. After the proper operating tension has been applied to the belts, double check the following: A) Parallel position of the sheave shafts. B) Correct alignment of sheave grooves. <p><i>Tensioning rules and procedure courtesy of Dodge PT Manual MN-4002</i></p>
-----------	---	--

4B.1

Tensioning Table





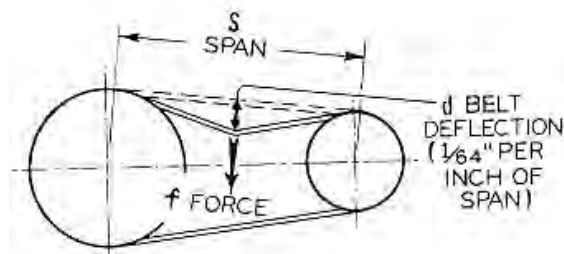

V-Belt Section	Small Sheave		Deflection Force			
	Speed Range	Diameter	1.0	1.5	2.0	4.0+
3VX	1200-3600	2.2	2.2	2.5	2.7	3
	1200-3600	2.5	2.6	2.9	3.1	3.6
	1200-3600	3	3.1	3.5	3.7	4.2
	1200-3600	4.1	3.9	4.3	4.5	5.1
	1200-3600	5.3	4.6	4.9	5.1	5.7
	1200-3600	6.9	5	5.4	5.6	6.2
5VX	1200-3600	4.4	6.5	7.5	8	9
	1200-3600	5.2	8	9	9.5	10
	1200-3600	6.3	9.5	10	11	12
	1200-3600	7.1	10	11	12	13
	900-1800	9	12	13	14	15
	900-1800	14	14	15	16	17
8VX	900-1800	12.5	18	21	23	25
	900-1800	14	21	23	24	28
	700-1500	17	24	26	28	30
	700-1500	21.2	28	30	32	34
	400-1000	24.8	31	32	34	36
5V	900-1800	7.1	8.5	9.5	10	11
	900-1800	9	10	11	12	13
	900-1800	14	12	13	14	15
	700-1200	21.2	14	15	16	17
8V	900-1800	12.5	18	21	23	25
	900-1800	14	21	23	24	28
	700-1500	17	24	26	28	30
	700-1200	21.2	28	30	32	34
	400-1000	24.8	31	32		36

Tensioning Table and installation image courtesy of Dodge PT Manual MN-4002

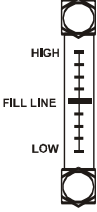
Notes:

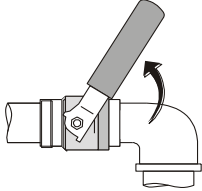
1. Use approximately 130% of above values to tension a new set of belts.
2. Use closest sheave diameter for sizes not shown.

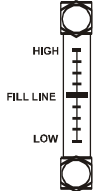

5	<p>Check fluid level in separator reservoir. The fluid level should be at the FILL LINE on the sight gauge. If gauge level is low, do not add oil. Systems are given a full charge of oil at DEKKER factory. Before filling, run unit at normal vacuum conditions for a few minutes, then shut down and fill to correct fluid level.</p> <p>Note: Fluid level may vary depending on vacuum level. Deep Vacuum (>25"HgV) requires more oil, but Low Vacuum (<15"HgV) can blow oil into outer shell. Both of these conditions will appear as lower oil in the sight-glass. Refer to Troubleshooting for additional details.</p>	
6	<p>If your system contains an inlet valve in the vacuum line, set it to approximately 3/4 closed, and start pump. If valve is not supplied, one should be installed.</p> <p style="text-align: center;"></p> <p>Warning: Do not operate pump with suction open to atmosphere for long periods of time.</p> <p>Note: Ideal vacuum is > 15"HgV at sea level.</p> <p>Note: This is an Air Inlet Valve, not an Oil Valve.</p>	
7	<p>Run the pump for a few minutes then turn it off.</p> <p>If unit is equipped with vacuum relief valve, valve is typically preset at 27"HgV at sea level.</p> <p>Note: For pump priming capacity, see the Maintenance Section of this manual, page 22. However, pumps are primed from the factory.</p>	
8	<p>With the pump shut off, check fluid level again. The fluid level should be at the FILL LINE on the sight gauge. Add fluid if necessary.</p> <p style="text-align: center;"></p> <p>Warning: Never remove the oil fill plug while the pump is running.</p>	
9	<p>Start pump again and check that discharge pressure on the separator does not exceed 2 psig when operating under vacuum conditions. A pressure higher than 2 psig is a sign of high back pressure in the discharge pipe system. Display might show a higher pressure at start-up at low vacuum (0-10"HgV).</p> <p>Note: Nominal operation should be less than 2 psig.</p>	
10	<p>Check the voltage and motor current. They should be within the specifications for the motor. Amperage should be checked at the Overload.</p> <p>Note: This test should also be performed under normal system operating conditions.</p>	<p style="text-align: center;"></p> <p style="text-align: center;">DANGER: HIGH VOLTAGE! Lethal shock hazard present. USE EXTREME CAUTION!</p>

11	After 15-30 minutes of operation, check pump operating temperature, which should be in the 140° - 185°F range.	
12	Remove temporary inlet screen.	

SHUT DOWN PROCEDURES

To stop vacuum system follow the procedure as outlined below.

Push the STOP button or turn switch to the OFF position. The inlet check valve will prevent fluid from the system from flowing back into the inlet manifold.

Note: If inlet piping could be under vacuum for an extended period of time without the pump running, inlet piping should be vented to atmosphere unless the process requires otherwise.

Note: Close the seal fluid isolation valve and the pump inlet isolation valve during extended periods of storage or when transporting. See Storage section on page 8 for details. Open valves before starting system.

MAINTENANCE



WARNING: Before attempting any maintenance such as changing the fluid, disconnect all power from the system by switching off the main breaker, isolate all energy sources and allow system to cool.

Pump Bearing Lubrication

Refer to pump series manual for details.

Motor Bearing Lubrication (where required)

For information regarding motor bearing lubrication, refer to the motor maintenance and operation manual.

Inlet Filter (If Installed)

Check after first 8 hours of operation. Clean or replace inlet filter element every 1000 to 3000 hours depending on application or if excessive pressure drop is noticed. In some applications it may be necessary to clean inlet filter more often. Clean filters by gently knocking off into a dust bin. Brush filter free of debris and clean with a wet/dry vacuum cleaner. **DO NOT USE COMPRESSED AIR TO CLEAN ANY FILTERS!**

CAUTION: Be careful not to allow foreign material to fall in the pump suction opening when removing the filter cartridge. Horizontal filter installation is recommended to prevent this. Filters must be disposed of properly as they might contain toxic substances carried over from the process.

Seal Fluid

The system(s) are shipped with DEKKER's specially formulated Vmaxol seal fluid. These fluids are specifically designed for use in DEKKER Vmax systems, providing low viscosity, excellent water separating qualities, anti-foaming and low oxidation. DEKKER recommends that Vmaxol sealing fluids be used for obtaining ultimate performance from the Vmax vacuum pump system and to preserve the extended 3-year warranty period.

When using Standard Vmaxol it is recommended that the seal fluid be changed every 10,000 hours of operation. When using Synthetic/Food grade Long-life Vmaxol, seal fluid may be changed every 15,000 hours of operation. Extreme operating conditions may require more frequent changes.

Oil Change Procedure

To change the fluid, first make sure there is no power to the system and the pump is off. We recommend that the fluid be changed when the system is at operating temperature. **CAUTION:** Oil will be hot.

To ensure that all seal fluid is removed, drain at all ports labeled below. Failure to service any of these ports will eventually result in premature failure of the system.

When charging the system with new fluid, make sure that the pump is filled with oil to the shaft centerline level. **Do not fill the pump above the shaft centerline.** Starting the pump with oil level above the shaft centerline may result in shaft or impeller damage or failure. You can add oil by removing the suction or discharge flange and pouring oil through pump suction or discharge port.

Fill the reservoir to the FILL LINE on the sight gauge. Open the air bleed valve on the heat exchanger to remove all air from the system. Run the pump for a few minutes, stop and check fluid level again. If required, add additional fluid to the reservoir. **Be sure not to overfill. Unscrew the Brass Push-Lock Fitting, and check port 'D' for excess oil.**

Check seal fluid level in the reservoir. A high fluid level could mean a build-up of water in the reservoir, which should be drained. **Since water settles below oil, drain from port 'C' until only the oil drains.** Check every 500 hours.

VMX0203-VMX0553

- A. Pump Drain (Ball Valve)
- B. Y-Strainer (Hex Plug/Mesh Screen)
- C. Inner Shell Drain (Pipe/Hex Plug/Ball Valve)
- D. Outer Shell Drain (90 Degree Brass Push-Lock Fitting) Sight Glass does not read from this Outer Shell. Before adding oil when you see it low in the sight glass, check for carried-over oil here.
- E. Heat Exchanger Drain (Hex Plug/Ball Valve)

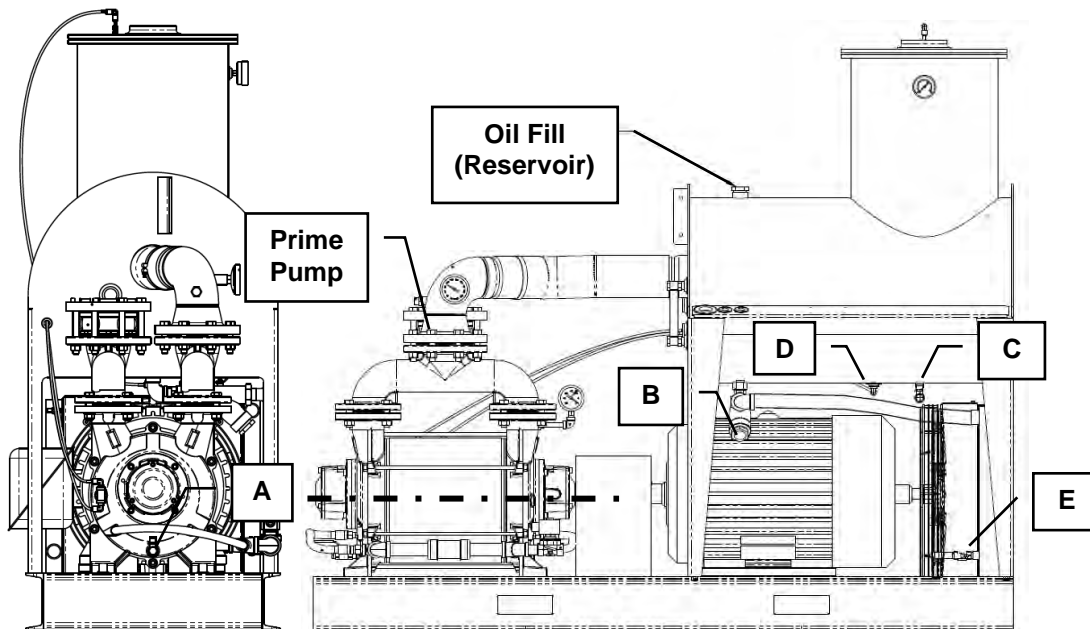

VMX0063-VMX0153

- A. Pump Drain (Typically Plugged) Not Shown; Face of Pump 6 o'clock position
- B. Y-Strainer (Hex Plug/Mesh Screen)
- C. Main Tank Drain (Ball Valve)
- D. Separator Scavenge Line Drain (90 Degree Brass Push-Lock Fitting)
- E. Heat Exchanger Drain (Hex Plug/Ball Valve)

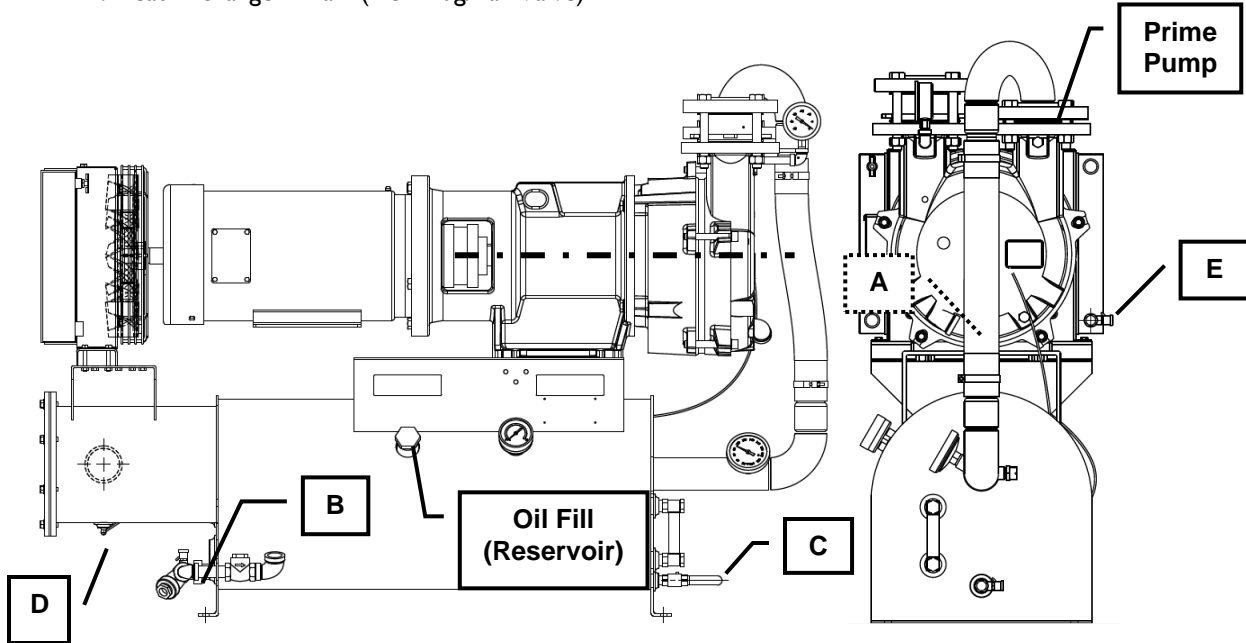

VMX0036

- A. Pump Drain (Typically Plugged)
- B. Y-Strainer (Hex Plug/Mesh Screen)
- C. Main Tank Drain (Ball Valve)
- D. Separator Scavenge Line Drain (90 Degree Brass Push-Lock Fitting) Not Shown; Under Separator Element Housing
- E. Heat Exchanger. Disconnect Hoses/Piping to Drain

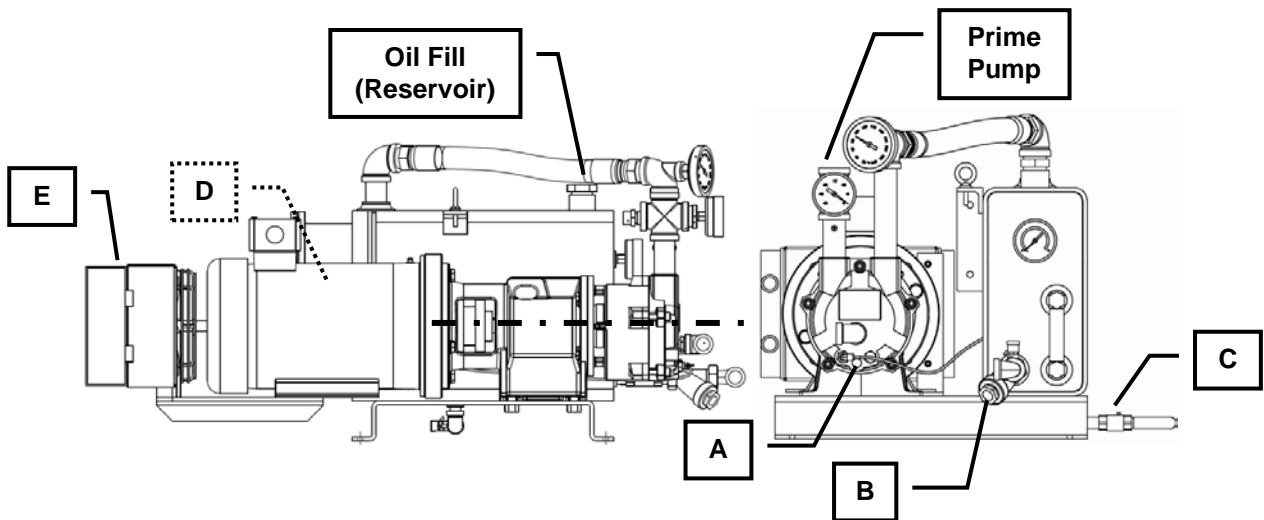

Standard System Capacities

System	Capacity (gal)	System	Capacity (gal)
VMX0036MAI-XX	1.6 gal	VMX0303KAI-XX	11 gal
VMX0063MAI-XX	4.5 gal	VMX0453KAI-XX	16 gal
VMX0083MAI-XX	4.75 gal	VMX0553KAI-XX	17 gal
VMX0103MAI-XX	6 gal	VMX0653KAI-XX	34 gal
VMX0103KAI-XX	6.5 gal	VMX0753KAI-XX	34 gal
VMX0153MAI-XX	6.25 gal	VMX1003KAI-XX	37 gal
VMX0153KAI-XX	7.25 gal	VMX1103KAI-XX	37 gal
VMX0203KAI-XX	10.5 gal	VMX1203KAI-XX	39.5 gal

Priming the Pump

Below is a table showing the amount of seal fluid needed to prime the pump.

Pump	Fluid Volume (qt.)	Fluid Volume (gal)
DV0035	0.5	0.1
DV0060	1.5	0.4
DV0080	1.9	0.5
DV0100	2.2	0.5
DV0150	4.7	1.2
DV0200	5.6	1.4
DV0300	7.2	1.8
DV0450	11.1	2.8
DV0550	14.6	3.7
DV0750	18.4	4.6
DV1200	36.1	9

Complimentary Oil Analysis

DEKKER offers oil analysis to customers, regardless of the age of their system, at no charge. Collect approximately 4 fluid ounces from the machine, and secure it in any type of clean bottle. On the bottle or a packing list, please include the following: system serial number, the type of oil, the run hours on the oil and machine, and note any problems you are having with the system if applicable.

Also make sure to include your contact information with email address. After the analysis is complete, DEKKER will provide a report of the condition of the oil, along with recommendations.

Send to:

DEKKER Vacuum Technologies, Inc.
 935 S. Woodland Ave.
 Michigan City, IN 46360
 United States
 ATTN: After Sales

Oil Solenoid Valve

The oil solenoid valve, if equipped, is located in seal fluid piping near the pump. The valve prevents oil from filling the pump on shutdown. It is critical that this valve operates properly. If the valve malfunctions in an open position, oil will flow back into the pump when the system is shut off. This will result in hard starting and possible equipment damage.

If the valve is stuck in the closed position, poor vacuum performance will result. If the pump is operated for longer than a minute without oil, internal damage may occur. The condition of the solenoid valve interior will mirror the condition of the oil reservoir housing. If there is a buildup of sludge, varnish, or particulate in the oil reservoir, the solenoid valve body may be likewise contaminated.

Seal Fluid Strainer

After the first 50 hours of operation, clean the strainer in the seal fluid line. This is done to remove any debris carried over into the system from the process. Clean and inspect the strainer every 1000-3000 hours depending on application or if excessive oil discharge temperature (above 185°F) is indicated. An increase in pump discharge oil temperature is an indication of low oil flow and normally is an indication of strainer blockage. If cleaning of strainer does not decrease temperature check the seal fluid line for blockage.

Separator Element

The separator element(s) is located in the separator reservoir. The purpose of the separator element is to remove the oil from the discharge air. Replace the element every 10,000 hours or once a year. Earlier replacement may be necessary when the back pressure is higher than 4 psig. High back pressure could be a result of contaminants on the separator element due to oil varnish or contaminated inlet gas stream. Replacement may vary depending on application.

NOTE: Thread-in style filters are installed hand-tight. Do not over-tighten with a wrench.

Separator Element Oil Return Line

The separator element oil return lines are 1/8" to 3/8" transparent tubing. The purpose of these lines is to remove excessive oil build-up from inside the separator and separator element. If excessive smoking or oil mist is present check the oil return lines for blockage and replace if necessary. Also check that the steel section of oil return line located on top of the separator reservoir is cut at a 45° angle and is touching the bottom of the separator element.

Shaft Seals

All DEKKER oil-sealed liquid ring vacuum pumps are fitted with mechanical shaft seals. Mechanical seals do not require maintenance unless there is more than a small amount of leakage. To define this we differentiate between the following:

Weepage: Mechanical seals work by having two flat surfaces pushed together by axial force from the closing mechanism and by product pressure in the seal chamber. When the seal is in operation, the seal fluid lubricates the two faces. This thin film of lubrication protects the faces of the seal from heat and excessive wear, but it can also allow for a small amount of leakage across the seal face. This small leakage is called a "weep". While a weep has rather arbitrary limits, it is commonly considered to be a leakage rate of less than one drop of liquid every minute. Seal weeps are not covered under warranty.

Leakage: A leakage rate of more than one drop per minute is considered to be a "leak". Seal leakage is normally a result of a build-up of abrasive particles carried over in the pump suction. These particles cause excessive wear on the seal faces. Leakage caused by wear and tear is not covered under warranty.

Seal replacement is addressed in the assembly and disassembly instruction for the specific pump model used. Consult factory for assistance.

Particles and debris that enter seal fluid can work into the sealing faces of the mechanical seals. Any debris pulled into the pump will mix with the seal fluid.

VMAX systems equipped with mechanical seal scavenger tubing must be monitored for oil flow through the lines after startup. If oil is present in the scavenger tubing, the seals may be leaking and replacement should be scheduled.

MAINTENANCE SCHEDULE

To help ensure trouble free system operation, a basic maintenance schedule consisting of the following system checks is recommended.

First 8 Hours of Operation

- Check oil level
- Check inlet filter element if installed
- Clean strainers and remove temporary inlet screen
- Check for water in sight gauge and drain if necessary
- Check piping for signs of oil leakage and tighten if necessary
- Check belt tension, if applicable

Daily

- Check oil level
- Inspect for leaks
- Check for water in sight gauge and drain if necessary
- Check piping for signs of oil leakage and tighten if necessary
- Check for oil in scavenger tubing. VMAX systems equipped with mechanical seal scavenger tubing must be monitored for oil flow through the lines after startup. If oil is present in the scavenger tubing, the seals may be leaking and replacement should be scheduled.

500 Hours of Operation

Under normal operating conditions repeat the **daily** steps above and,

- Check inlet filter element if installed
- Clean strainers and remove temporary inlet screen

1000 Hours of Operation

- Check back pressure on separator element; it should not exceed 4 psig. Change separator element if back pressure exceeds 4 psig. Also, check discharge pipe system for blockage.
- Clean or replace inlet filter element.
- Remove debris from pump housing, motor fan guard, and heat exchanger.
- Applicable to pumps equipped with grease fittings located on each bearing housing. Grease bearings with a quality #2 lithium grease. Do not over-grease, 3 to 4 pumps with a grease gun is sufficient under normal conditions.

10,000 Hours of Operation

- Every 10,000 hours, or annually, change seal fluid. Use DEKKER Vmaxol seal fluid. Life of Standard Vmaxol is 10,000 hours of operation. Synthetic/Food grade long-life Vmaxol may be changed every 15,000 hours of operation.
- Change separator element if back pressure exceeds 4 psig.
- Check coupling element for wear. Replace if worn.
- Clean strainer in seal fluid line.

30,000 Hours of Operation

- Every 30,000 hours, or every 5 years, it is recommended that you replace the vacuum pump's mechanical seals and bearings as preventative maintenance. This should be done by a DEKKER authorized distributor or properly trained service technician.

Devarnishing

The operating life of the unit is greatly enhanced based on the quality of the seal fluid. Oxidized or darkened seal fluid is a sign of trouble. Plugged filters reduce performance and may damage pump. Periodic maintenance will offer the best protection for your equipment.

DEKKER offers a specially formulated devarnishing compound Proclean 39V for oil-sealed liquid ring pumps and systems. Procedure for using Proclean 39V and SDS sheet are included with the product.

NOTE: Varnished pumps are not covered under warranty.

ACCESSORIES AND PROTECTIVE DEVICES (IF INCLUDED)

Accessories

The following accessories are available for Vmax oil-sealed liquid ring vacuum pump systems.

- **Inlet or Discharge Flexible Connectors (optional):** These flex connectors are used in piping systems to eliminate vibration transmission from machinery throughout the piping network.
- **Vibration Isolators (optional):** Vibration isolators are used to eliminate vibrations, noise and shock transmission from machinery to the floor. Floor-mount type vibration isolators are used for Vmax vacuum pump systems.
- **System Isolation Valve (optional):** This valve may be installed on the vacuum receiver tank or vacuum pump manifold. Usually the valve is used to isolate the vacuum system from the piping network.
- **Inlet Filter (optional):** An inlet filter may be installed on the Vmax oil-sealed vacuum pump systems to prevent carry-over of particles into the pump.
- **Vacuum Relief Valve (optional):** This valve may be installed on the pump suction manifold or on the receiver. The vacuum relief valve is used to protect the vacuum pump from closed suction which can damage the pump.

Protective Devices

The following protective devices are available to protect the unit from being damaged and to help with maintenance:

- **High Temperature Switch (optional):** The switch will signal when the temperature of the seal fluid is exceeding the shut-down level. The switch will shut the unit down. The unit will not restart until the alarm condition is acknowledged and is reset. The switch is a “snap disc” type of switch that is normally closed. When the temperature reaches the maximum set point, the switch will open. Once the switch has opened, there is a 10°-20°F differential that the temperature will need to drop to, in order for the switch to close.
- **High Back-Pressure Switch (optional):** This switch is installed on the discharge of the separator. When the back-pressure reaches a pre-determined level (4 psi), the switch will signal the control panel. A high back-pressure light may be installed on the control panel, which, when illuminated, signals that the exhaust element in the vacuum pump needs to be replaced. Note that the high back-pressure switch will not shut the unit down, but the exhaust element must be replaced as soon as possible.
- **Low Oil Level Switch (optional):** This switch is installed in the separator/reservoir of the liquid ring vacuum pump. It is a float type of switch. If the level switch is triggered, the affected pump will shut down. The LOW OIL LEVEL light on the control panel will be illuminated. The low level switch will be wired into the main alarm of the panel. The alarm will have to be reset to restart the pump. When filling the system with oil, make sure that the power to the pump is off because if the alarm reset button has been reset and the level switches contacts close while filling the pump, the pump will start-up automatically.

- **High Oil Level Switch (optional):** This switch is installed in the separator/reservoir of the liquid ring vacuum pump. It is a float type of switch. If the level switch is triggered, the affected pump will shut down. The HIGH OIL LEVEL light on the control panel will be illuminated. The high level switch will be wired into the main alarm of the panel. The alarm will have to be reset to restart the pump. When draining the system, make sure that the power to the pump is off because if the alarm reset button has been reset and the level switches contacts close while draining the pump, the pump will start-up automatically.

TROUBLESHOOTING

The following is a basic troubleshooting guide and not all options may be included. Service should be done by a DEKKER authorized distributor or a properly trained service technician. Each unit is tested and checked at the factory. Always indicate model and serial number when calling. The model and serial number is viewable on the gold-colored information plate attached to the unit.



WARNING: Before attempting any maintenance such as changing the fluid, disconnect all power from the unit by switching off the main breaker, isolate all energy sources and allow unit to cool. All electrical work should be done by a qualified electrician in compliance with OSHA, National Electric Code and any other applicable local electrical code.

Start-Stop Problems

Unit will not start

1. No main AC power. Confirm that the main AC power disconnect is ON and supplying power to the control panel. This can be measured with an AC voltmeter at the power supply terminals in the control panel. Refer to the electrical control panel diagram supplied with the system. If main AC power is not present at the power supply, verify incoming AC voltage on the motor contactor.
2. Check if the disconnects or circuit breaker is switched on.
3. Check the overload setting on the starter and fuses.
4. Check the small auxiliary contactor on the face of the main contactor. A loose connection or debris can cause faulty operation. Remove, clean, and reattach. Tighten wires.
5. Check alarm reset, light should be off.
6. Ensure that the proper voltage is supplied and that the wire size is correct.
7. Check electrical control panel. Make sure that all wires are tight. Wires may vibrate loose during shipment or operation.
8. Check low oil level switch. Add oil to reservoir if needed.
9. Check high oil level switch. Drain oil from reservoir if needed.
10. Check if the pump has seized by rotating the coupling by hand (disconnect power first). If a rubbing noise or binding is observed, contact authorized dealer.

Unit shuts down while running

1. Check operating temperature.
2. Check the overload setting on the starter and fuses.
3. Ensure that the proper voltage is supplied and that the wire size is correct.
4. Check for loose electrical connections.
5. Check the vacuum set points.
6. Check low oil level switch. Add oil to reservoir if needed.
7. Check high oil level switch. Drain oil from reservoir if needed.
8. Check if the pump has seized by rotating the coupling by hand (disconnect power first). If a rubbing noise or binding is observed, contact authorized dealer.
9. Clean oil strainer.
10. Check if pump operates against high back pressure (> 4 psig), if so replace oil separator element.
11. Check the small auxiliary contactor on the face of the main contactor. A loose connection or debris can cause faulty operation. Remove, clean, and reattach. Tighten wires.

Vacuum Problems

Unit Operates, but does not achieve desired vacuum level

1. Stop system and disconnect power.
2. Check if the inlet valve is open and inlet filter is clean.
3. Ensure that no lines are open to the atmosphere, causing loss of vacuum.
4. Check for leaks in piping systems, using conventional leak detection methods.
5. Ensure oil level is correct, pump is primed and filled with oil to the shaft centerline only.
6. Check if the oil isolation valve is open.
7. Check if the oil solenoid valve is working.
8. Check the vacuum set points.
9. Check setting of vacuum relief valve and adjust as needed. The valve is typically preset at 27" HgV at sea level.
10. Check if the motor rotation is correct. Rotation should be clockwise (facing pump from motor side) and marked by an arrow on the motor or pump housing. If incorrect, switch any two of the three main power leads on the contactor inside the control panel.

Overheating Problems

Unit overheats or operates above 200°F

1. Stop system and disconnect power.
2. Check the oil cooler and fan. Clean cooler externally with compressed air. Ensure that 12" of space is available in front of the cooler and that the ambient temperature is below 104°F.
3. Check if the oil isolation valve is open.
4. Check if the oil solenoid valve is working.
5. Ensure oil level is correct, pump is primed and filled with oil to the shaft centerline only.
6. Check if the temperature control valve is working and that oil is flowing through the cooler.
CAUTION: Oil will be HOT.
7. Clean oil strainer.
8. Check if oil cooler is blocked internally with solids passed through from the process.

Unit overheat on start-up in low ambient temperatures

1. Stop system and disconnect power
2. Oil tends to thicken in temperatures of 45°F and below. Place heat tape and insulation on the fluid seal line from the heat-exchanger to the pump inlet.
3. Also insulate the seal-fluid solenoid valve or change oil to synthetic fluid contact authorized dealer or the factory for more information.

Noise and Vibration Problems

The system is making an abnormal noise or sound

1. Stop system and disconnect power.
2. Check the coupling and/or element for proper alignment. If worn or damaged, replace.
3. Check if the bearings are greased. Rotate the coupling by hand, which should rotate freely. If a rubbing noise or binding is observed, contact authorized dealer.
4. Ensure oil level is correct, pump is primed and filled with oil to the shaft centerline only.
5. Check setting of vacuum relief valve and adjust as needed. The valve is typically preset at 27" HgV at sea level.
6. Check the inlet filter and clean if necessary. Pump may hydraulically knock / cavitate if filter is blocked.
7. Check if the inlet valve is closed. The pump may hydraulically knock / cavitate if inlet is closed.
8. Check vacuum level. Pump may hydraulically knock / cavitate as a result of too deep of a vacuum level.

System is vibrating excessively

1. Stop system and disconnect power.
2. Check the coupling and/or element for proper alignment. If worn or damaged, replace.
3. Check if the bearings are greased. Rotate the coupling by hand, which should rotate freely. If a rubbing noise or binding is observed, contact authorized dealer.
4. Check if baseplate is properly supported. Uneven floor will distort baseplate, which could cause vibrating problems.
5. Check that the mounting bolts of pump, coupling, fan and cooler are not loose. Tighten as required.
6. Check belt alignment on belt drive systems.

Oil Problems

System uses excessive oil or produces an oil-mist

Stop system and disconnect power.

1. Check the oil return line from the separator for blockage to ensure that oil flows from separator to vacuum pump.
2. Check if pump operates against high back pressure (> 4 psig), if so replace oil separator element.
3. Normal and continuous operating vacuum level should be 15" HgV or deeper. If not, contact authorized dealer or the factory.
4. Check for an excessive amount of water vapor carried over from the process in the oil reservoir by slowly draining from separator drain. Remove all excess water.

Troubleshooting Quick Reference Guide

Issue	Cause	Remedy
Start Stop Issue	No main AC power in panel	Confirm disconnect is on and fuses are good
	No 24VDC power in panel	Check fuse and bottom connection
	Overload is not set correctly	Set according to motor data FLA X SF
	Alarm overload is tripped	Reset overload
	Loose wires	Check all incoming and panel wires
	Low level switch is engaged	Add fluid if necessary
	Pump has seized	Check shaft spin by hand at coupling, if froze, contact factory
	Vacuum Set points are not set properly	Set according to Controller Manual
	Main Breaker trips immediately upon start up	Check motor connection/windings Pump is flooded
Low Vacuum	Inlet Valve is closed	Open valve
	Lines or process is open to atmosphere	Seal all open areas
	Leaks in piping	Check and correct piping leaks
	Pump is not primed	Check pump to ensure it has oil to create the liquid ring
	Fluid Supply valve is closed	Open valve, and check pump for prime
	Motor rotation is backward	Check and change rotation as needed
	Inlet filter element is clogged with contamination	Clean or change filter element
	Vacuum set points are not set properly	Set according to Controller Manual
	Solenoid valve not working	Check wires, voltage to coil, or obstruction from contamination
Vacuum relief valve fail	Check valve for adjustment or replace	
Overheating	Radiator fins are clogged	Check and clean debris in fins
	Radiator is blocked internally	Check temperature drop across cooler when running, should be 25 F delta Check and clean y-strainer screen
	Loss of fluid flow	Check if fluid supply valve is open
		Check if solenoid valve is functioning
	Thermostat valve (if installed) is not opening	Replace element
Running at low vacuum levels	Operate system at no less than 15" HgV	
Noise and Vibration	Coupling is misaligned or broken	Align and change element as needed
	Check bearings in motor and pump	Rotate coupling by hand, if rubbing or binding, call factory
	Pump hydraulic noise at deep vacuum	Pump is cavitating, open inlet to allow some air in
	System baseplate is not secure	System should be on level surface and supported
	Mounting bolts or piping is loose	Check all bolts on system, and secure piping
Oil Mist or Carryover	Running at low vacuum levels	Operate system at no less than 15" HgV
	Exhaust separator element needs service	Check back pressure, change filter as needed
	Scavenge line on tank and separator has blockage	Clean lines and ports as needed
	Excessive water carried over from process	Remove all excess water from separator tank at drain
Mechanical Seal Leaks		Change fluid
	Contamination in fluid	Change inlet filter
	Pump was ran without fluid	Change seal, ensure fluid supply lines are open, and pump is primed