

POWEREX[®]



Scroll Enclosure Systems

Industry-leading, quiet, reliable, compact air system

OIL-LESS SCROLL



Patented grease-able pin crank bearings

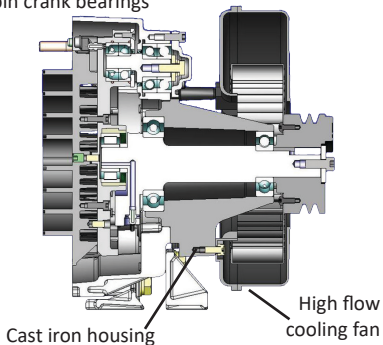

Our innovative scroll technology is completely oil-less, extremely quiet, and energy efficient. The scroll pump has few moving parts, making it reliable and easier to maintain. The self lubricating tip seals and absence of a gearbox means the pump is truly 100% oil free. As the leaders in scroll pump technology, our latest design incorporates several innovative features:

- Main bearings are housed in durable cast iron instead of aluminum which prevents fretting and premature failure of the bearing race. This pump can be operated at 100% duty with confidence.
- The patented bearing re-grease feature has been improved to allow maintenance from the front side of the pump, cutting service time in half.
- The patented tip seal design yields the highest flow rates and longevity of any other dry scroll compressor.
- The improved efficiency and cooling results in lower operating temperatures.
- Extremely low vibration.
- Industry first 10hp scroll pump improves system efficiency by producing more output using fewer pumps.

HOW IT WORKS

As the scroll orbits, a crescent-shaped cavity is gradually reduced, compressing the air and exhausting it through the final discharge point at the center. During operation, all the gas passages are in various stages of compression at all times, resulting in nearly continuous compression and discharge.

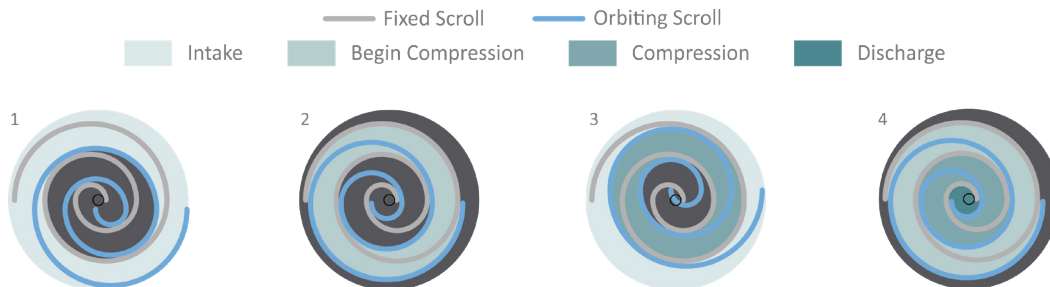

ENERGY EFFICIENCY

With the Powerex Variable Pump Drive system, each compressor pump is automatically staged on/off individually based on actual system demand, maximizing energy efficiency at all usage levels. Lead compressor status will alternate every time a pump is called for – or every 10 minutes, whichever comes first – which maintains equal run hours and extends maintenance intervals.

Redundancy is built into our system with our multiple pump design, eliminating the need to purchase an additional compressor.

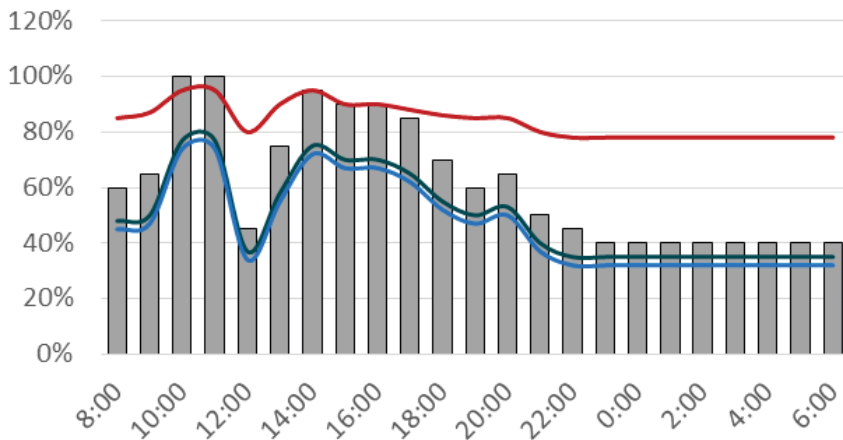

Redundancy is built into our system with our multiple-pump design

- Plant Load Factor
- Scroll Compressor Electric Consumption
- Air Consumption of Plant
- Screw Compressor Electric Consumption

WhisperAIR™ SOUND ENCLOSURE CABINET

Powerex's trademarked oil-free enclosure systems offer the lowest noise levels in the industry. Each system is packaged in a rigid steel frame with powder coated panels and lined with sound-deadening insulation. The low noise levels are unmatched in the industry and allow installation at the point of use, while the small footprint simultaneously maximizes floor space.

WhisperAIR™
OIL-LESS
SCROLL



SCROLL ENCLOSURE SYSTEMS FEATURES

3-5 HP SIMPLEX MODELS

- 3-5 HP systems are UL/CSA certified.
- Integral 13 gallon tank ASME/CRN.
- Inlet filtration with replaceable element.
- Front mounted control panel includes:
 - On/Off switch.
 - Power on light.
 - High temperature shutdown with indication light.
 - Run time hourmeter.
 - Pressure gauge.
 - Automatic start/stop operation.
 - Control voltage starter with motor overload protection.
- Internal vibration isolators.
- Air-cooled aftercooler.
- ODP Motor.

10-60 HP MULTIPLEX MODELS

- 10-20 HP systems are UL/CSA certified.
- Inlet filtration with replaceable element.
- Front mounted control panel includes:
 - On/Off switch.
 - Power on light.
 - High temperature shutdown with indication on the display.
 - Run time hourmeter for each pump.
 - Maintenance counter with alarm warning display.
 - System pressure display.
 - Full voltage starter with overload protection.
 - General compressor fault with remote contacts.
- Internal vibration isolators.
- Air-cooled aftercooler for each compressor.
- TEFC Motor.

ACCESSORIES & OPTIONS

- Air receivers 30-600 gal.
- Desiccant air treatment systems.
- Refrigerated air treatment systems.
- Remote inlet filters.
- Master lead/lag controllers for multiple cabinets.
- NFPA 99 compliant systems.
- Laboratory system packaging.
- CO monitor
- Dewpoint monitor
- 50Hz motors

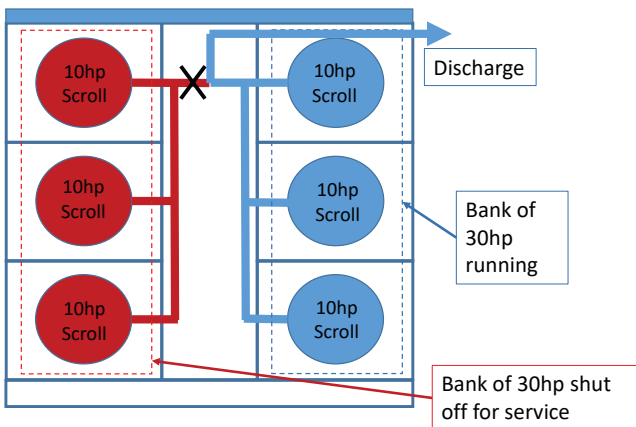

EASILY SERVICEABLE

Pump Bank Isolation on our 40-60HP systems provide ease of maintenance and service, allowing for the isolation of a compressor bank for service while the other bank continues to run.

- OSHA-approved service on half capacity while other half is running
- Electrically – motor protector disconnect and circuit breakers
- Mechanically – ball valves

SCROLL ENCLOSURE SYSTEMS SPECIFICATIONS

Standard Pressure Models						
Model	System HP	Pump HP	Maximum Pressure (PSIG)*	Standard SCFM @ 100 PSIG High Pressure SCFM @ 145 PSIG	Operating Pressure (PSIG)†	dB(A) Level
SES0208 ¹	2	2	116	5.7	95-115	49
SES0308 ^{1,2} SES0308HP ^{1,2}	3	3	116 145	8.8 7.1	95-115 115-145	49
SES0508 ^{1,2} SES0508HP ^{1,2}	5	5	116 145	15.2 12.5	95-115 115-145	51
SED1007 SED1007HP	10	5	116 145	30.5 25	90-116 115-145	53
SET1507 SET1507HP	15	5	116 145	45.7 37.5	90-116 115-145	56
SED15B7 SED15B7HP	15	7.5	116 145	46.2 34	90-116 115-145	63
SEQ2007 SEQ2007HP	20	5	116 145	61 50	90-116 115-145	58
SED20B7 SED20B7HP	20	10	116 145	62.4 49	90-116 115-145	64
SET2257 SET2257HP	22.5	7.5	116 145	69.3 51	90-116 115-145	65
SEH3007 SEH3007HP	30	5	116 145	91.5 75	90-116 115-145	62
SET30B7 SET30B7HP	30	10	116 145	93.6 73.5	90-116 115-145	66
SEO4007 SEO4007HP	40	5	116 145	122 100	90-116 115-145	63
SEQ40B7 SEQ40B7HP	40	10	116 145	124.8 98	90-116 115-145	66
SEH45B7 SEH45B7HP	45	7.5	116 145	138.6 102	90-116 115-145	66
SEP50B7 SEP50B7HP	50	10	116 145	156 122.5	90-116 115-145	67
SEH60B7 SEH60B7HP	60	10	116 145	187.2 147	90-116 115-145	69

*Performance and maximum pressure shown at sea level conditions.

†Operating pressure range adjustable (consult factory for parameters).

¹ Single phase models use motors that require input voltage of 230V.

² Single phase 3 HP units require the installation of an additional 30 gal external tank and 5 HP units will require the installation of additional 60 gal external tank.

For more information contact your local Powerex distributor or Powerex sales representative today



The leader in oil-free air technology



HQ • 150 Production Drive • Harrison, OH 45030 • USA
100 Mundy Memorial Drive • Mount Juliet, TN 37122 • USA
T 1.888.769.7979 • F 513.367.3125 • www.powerexinc.com

 **Designed & Manufactured in the USA**
with U.S. and Imported Components



Powerex is a proud manufacturer of ISO 8573-1:2010 “Class Zero” Oil-free compressed air systems using oil-less scroll and oil-free rotary tooth technology. Powerex is located just outside of Cincinnati, OH, and is a leading manufacturer of oil-less compressed air and vacuum systems for medical gas, laboratory, and critical-process industrial applications. We are an ISO 9001:2015 manufacturing facility that is able to provide complete air systems including tanks, UL508A control panels, and dryers. Contact Powerex today to match you with the right compressor for your application.