

Why more and more customers are switching to the *Vmax*^{LT} system:

- ✓ The only system on the market with a **full 3-year warranty!**
- ✓ **Compact design** with all the **Vmax advantages** at the **cost of a similar capacity rotary vane pump.**
- ✓ Patented, **high-efficiency DX-5 separator** eliminates oil carry-over concerns.
- ✓ Rugged, **high-quality, industrial system**, offering years of **trouble free operation.**
- ✓ **Extended-life seal-fluid** is not used as a lubricant. Change interval is not critical, resulting in a minimum of **10,000 hours of continuous operation.**
- ✓ **UL/CSA EPACT-compliant motor-mounted design** eliminates the use of V-belts or couplings, resulting in very **low maintenance and zero downtime.**
- ✓ **Extremely low operating noise** level makes this system desirable in today's workplace.
- ✓ **Continuous operation over the full vacuum range** without overheating.
- ✓ **Carry-over** of soft solids and/or minimal amounts of liquid **does not cause damage** to the internal parts of the pump.
- ✓ **Air-cooled design** is **standard** with water-cooling available at no extra charge.

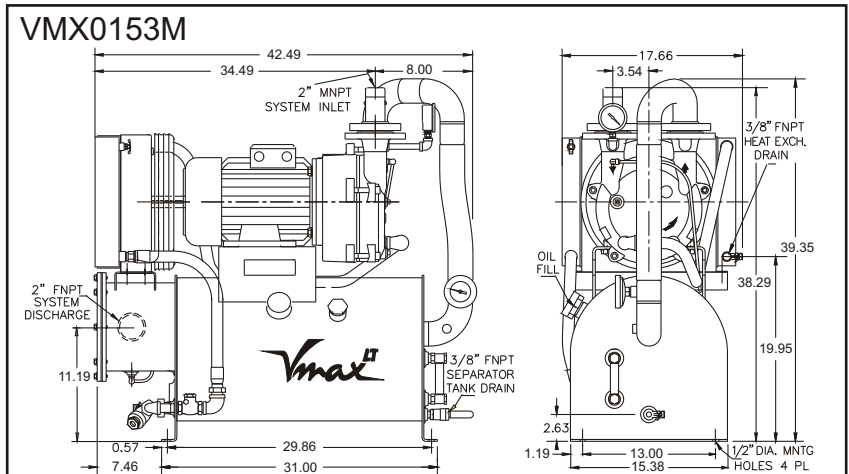
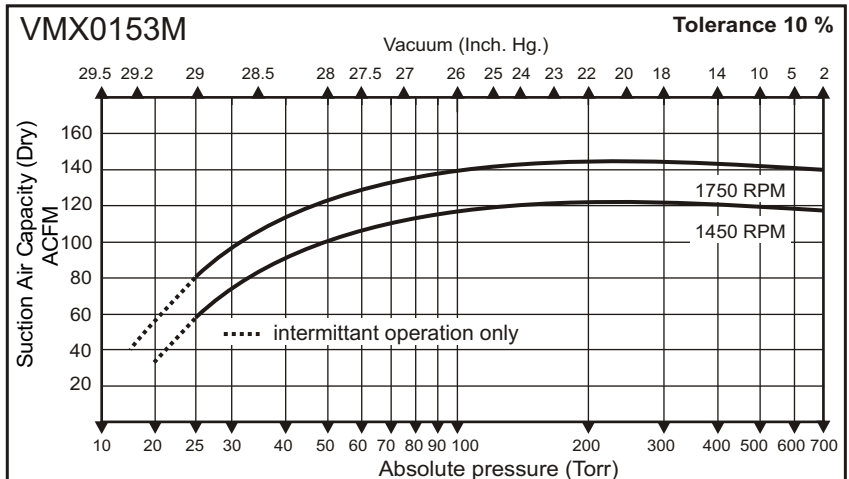
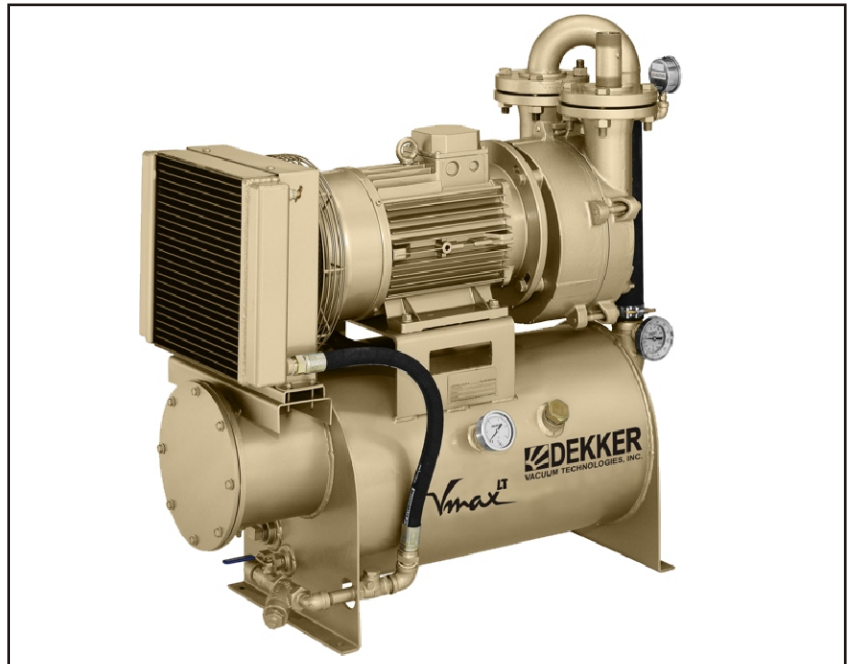

Performance Characteristics

Nominal capacity: 150CFM
 Motor: 50Hz/5.5kW/7.5HP - 60Hz/7.5kW/10HP
 Speed: 1450/1750RPM
 Maximum vacuum: 29"Hg/982mbar
 Weight (approximate): 293Kg/644Lbs
 Maximum gas inlet temperature: 212°F/100°C
 Maximum noise level (at 3 feet): 76dBA
 Oil capacity (approximate): 23Ltr /6 GAL
Performance based on atmospheric pressure equal to 29.92"Hg/1013mbarA

Information contained in this document is for reference only. Subject to change without notice.