

Mink

Claw Vacuum Pumps
MM 1104–1142 BV



- › **Efficient:**
energy-efficient,
low operating costs
- › **Nearly Maintenance-Free:**
dry and contact-free
compression
- › **Reliable:**
operationally reliable

Busch Mink claw vacuum technology for industrial vacuum generation offers the highest possible energy efficiency combined with low maintenance and a constant level of performance.

The sophisticated design of Busch claw vacuum technology allows Mink claw vacuum pumps to operate at extremely high efficiency levels, which has a positive effect on the pumping speed and energy consumption. In practice this means substantial energy savings for the same pumping speed when compared to conventional vacuum generators.

The contact-free operating principle of claw vacuum technology provides the additional benefit of nearly maintenance-free operation: none of the internal moving parts of the vacuum pump come in contact with each other, so components are not subject to wear. Servicing tasks such as inspection and replacement of worn parts are eliminated completely.

The proven, completely dry-running claw vacuum technology of Mink claw vacuum pumps allows them to run without operating fluids in the compression chamber. In practice this means no contamination of the pumped medium, and no environmental emissions. In addition, no costs arise for the purchase, replacement and disposal of operating fluids.

Mink claw vacuum pumps are air cooled, so no effort for the installation and maintenance of a cooling system is required. Their contact-free operating principle allows them to run extremely efficiently throughout the vacuum range and to deliver consistently high pumping speeds during their entire life cycle.

The outstanding reliability and long service lifetime of Mink claw vacuum pumps are also a result of the contact-free and dry compression. An intelligent sound insulation design allows Mink claw vacuum pumps to operate at low sound levels.

**Mink – efficient and reliable
vacuum generation.**



Mink MM 1142 BV

Mink

Claw Vacuum Pumps MM 1104–1142 BV



Technical specifications

Mink claw vacuum pumps feature two claw-shaped rotors that move in opposite directions, mounted in a housing. The shape of these claw rotors extracts, compresses (in two stages) and expels air or gas. The rotors do not come in contact with each other or the housing, so no lubricants or operating fluids are required in the compression chamber. The minimal clearance between the rotors and the chamber housing optimizes the internal seal and ensures constantly high pumping speeds. An effective air cooling system guarantees optimal operating temperatures. A synchronizing gearbox maintains precise rotor timing. Mink claw vacuum pumps are driven by a directly flange-mounted asynchronous motor of efficiency class IE 2/3.

Mink MM 1104–1142 BV

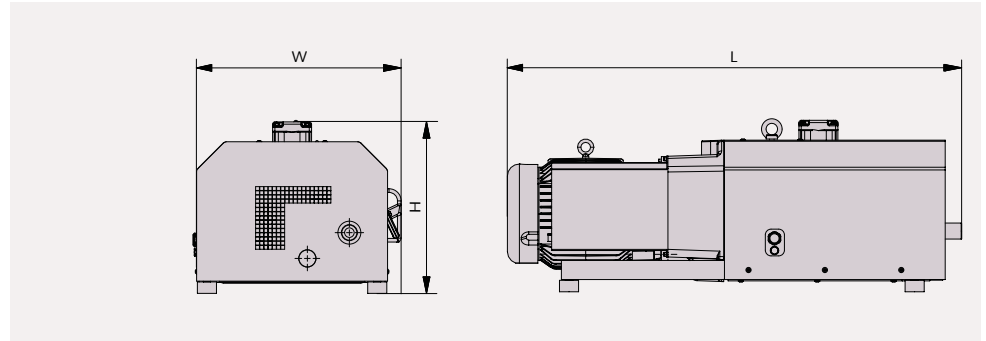

Pumping speed Air at 70 °F. Tolerance: ± 10%

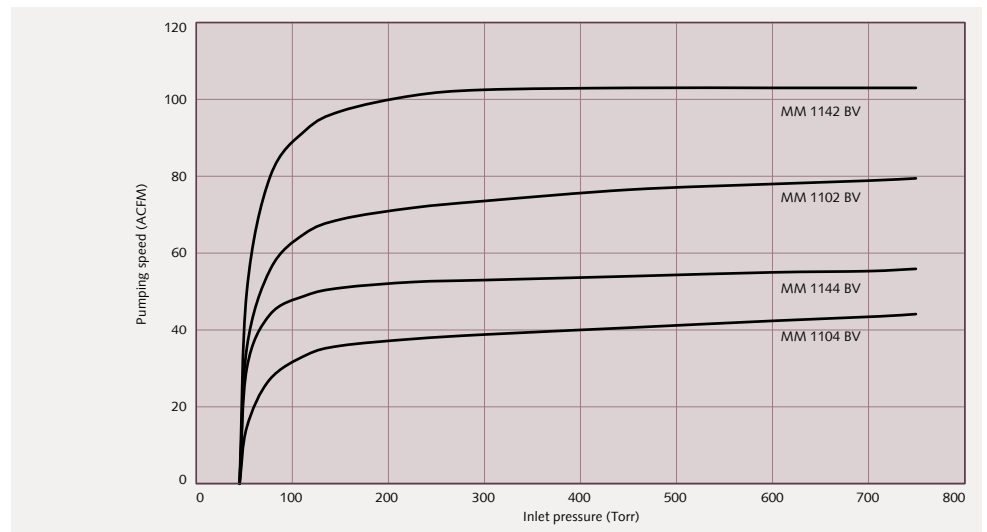

Technical data		MM 1104 BV	MM 1144 BV	MM 1102 BV	MM 1142 BV
Max. pumping speed	ACFM	44	57	79	103
Ultimate pressure	Torr	45	45	45	45
Nominal motor rating	HP	2	3	4	5
Nominal motor speed	RPM	1800	1800	3600	3600
Sound level (ISO 2151)	dB(A)	70	70	79	79
Approximate weight	Lbs.	439	448	443	449
Dimensions (L x W x H)	inches	39 1/2 x 17 x 16 1/8	42 3/4 x 17 3/4 x 16 1/8	42 3/8 x 17 3/4 x 16 1/8	42 7/8 x 17 3/4 x 16 1/8
Gas inlet / outlet	NPT	1 1/4" / 1"	1 1/4" / 1"	1 1/4" / 1"	1 1/4" / 1"

All performance data is based on ambient conditions of 14.7 PSIA and 70 °F, and has a tolerance of ± 10%.

Busch LLC

516 Viking Drive | Virginia Beach, VA 23452 | Phone 757-463-7800 | info@buschusa.com | www.buschusa.com

Argentina Australia België Brasil Canada Česko Chile 中國 Colombia Danmark Deutschland España France भारत गणराज्य Ireland ישראל Italia 日本 대한민국 Magyarország Malaysia México Nederland New Zealand Norge Österreich Perú Polska Portugal România Россия Schweiz Singapore South Africa Suomi Sverige 台灣 ประเทศไทย Türkiye الإمارات العربية المتحدة United Kingdom USA

Technical data is subject to change. Created in Germany. MG PL MINKMM11041142BV USenus 10/2016 6.0