

MINK

Claw Vacuum Pumps
MM 1402 AV, MM 1502 AV

Instruction Manual



Table of Contents

1	Safety	3
2	Product Description	4
2.1	Operating Principle	5
2.2	Intended Use	5
2.3	Design Options.....	6
2.3.1	Gas Tight Version	6
2.3.2	Aqua Version.....	7
2.4	Start Controls.....	7
2.5	Standard Features.....	7
2.5.1	Vacuum Relief Valve.....	7
2.6	Optional Accessories.....	7
2.6.1	Inlet Filter	7
2.6.2	Condensate Drain	7
3	Transport	8
4	Storage	9
5	Installation	10
5.1	Installation Conditions.....	10
5.2	Connecting Lines / Pipes	11
5.2.1	Suction Connection.....	12
5.2.2	Discharge Connection	12
5.3	Filling Oil.....	13
6	Electrical Connection	14
6.1	Machine delivered without Control Box or Variable Speed Drive (VSD).....	14
6.2	Wiring Diagram Three-Phase Motor	15
7	Commissioning	17
7.1	Conveying Condensable Vapors.....	17
8	Maintenance	18
8.1	Maintenance Schedule	19
8.2	Oil Level Inspection	19
8.3	Cleaning from Dust and Dirt.....	20
8.4	Oil Change.....	20
8.5	Pressure Relief Lines Maintenance (Gas Tight Version Only)	22
9	Overhaul	24
10	Decommissioning	25
10.1	Dismantling and Disposal	25
11	Spare Parts	26
12	Troubleshooting	27
13	Technical Data	29
14	Oil	30
15	EU Declaration of Conformity	31
16	UK Declaration of Conformity	32

1 Safety

Prior to handling the machine, this instruction manual should be read and understood. If anything needs to be clarified, please contact your Busch representative.

Read this manual carefully before use and keep for future reference.

This instruction manual remains valid as long as the customer does not change anything on the product.

The machine is intended for industrial use. It must be handled only by technically trained personnel.

Always wear appropriate personal protective equipment in accordance with the local regulations.

The machine has been designed and manufactured according to state-of-the-art methods. Nevertheless, residual risks may remain, as described in the following chapters and in accordance with the chapter *Intended Use* [→ 5]. This instruction manual highlights potential hazards where appropriate. Safety notes and warning messages are tagged with one of the keywords DANGER, WARNING, CAUTION, NOTICE and NOTE as follows:



DANGER

... indicates an imminent dangerous situation that will result in death or serious injuries if not prevented.



WARNING

... indicates a potentially dangerous situation that could result in death or serious injuries.



CAUTION

... indicates a potentially dangerous situation that could result in minor injuries.



NOTICE

... indicates a potentially dangerous situation that could result in damage to property.



NOTE

... indicates helpful tips and recommendations, as well as information for efficient and trouble-free operation.

2 Product Description

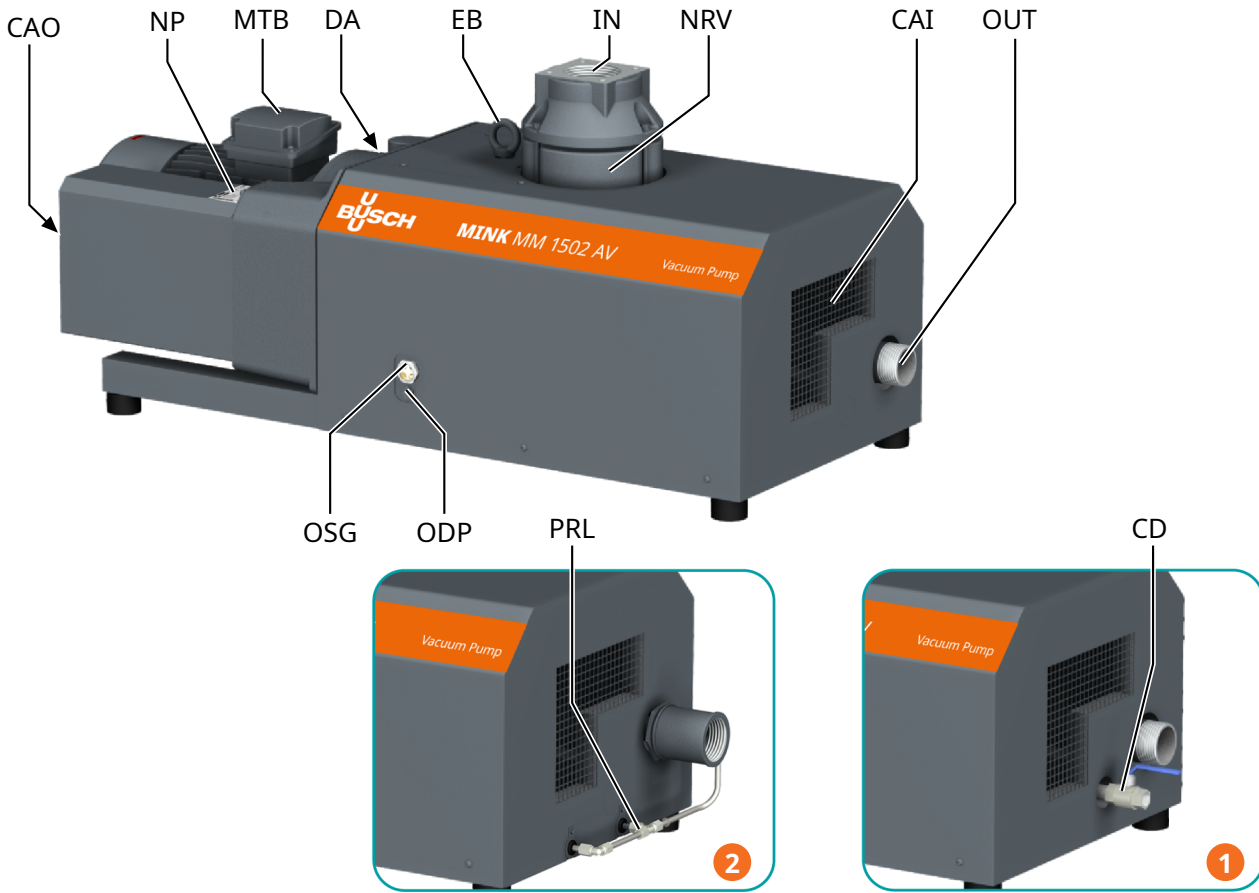

Description			
1	Aqua version	2	Gas tight version
IN	Suction connection	OUT	Discharge connection
OSG	Oil sight glass	ODP	Oil drain plug
CAI	Cooling air inlet	CAO	Cooling air outlet
MTB	Motor terminal box	NRV	Non-return valve (integrated)
EB	Eye bolt	CD	Condensate drain (optional)
PRL	Pressure relief line	DA	Directional arrow
NP	Nameplate		

NOTE

Technical term.

In this instruction manual, we consider that the term 'machine' refers to the 'vacuum pump'.

NOTE

Illustrations

In this instruction manual, the illustrations may differ from the machine appearance.



NOTE

Product origin

The serial number on the nameplate (NP) determines the manufacturing plant.

2.1 Operating Principle

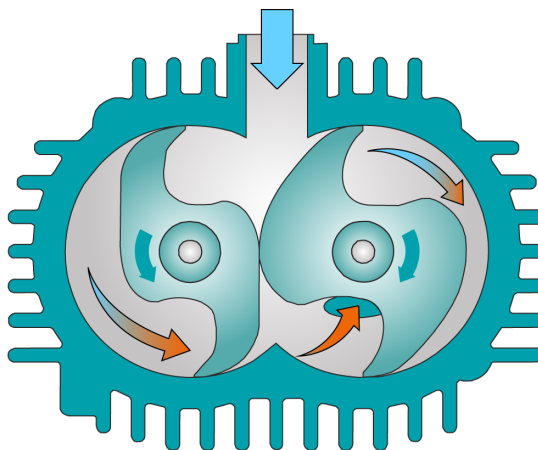

The machine works on the claw principle.

The MINK is fully air-cooled thanks to an integrated fan in the drive unit.

In order to avoid solids from entering, the machine is equipped with an inlet screen (IS).

In order to avoid reverse rotation after switching off, the machine is equipped with a non-return valve (NRV).

2.2 Intended Use



WARNING

In case of foreseeable misuse outside the intended use of the machine.

Risk of injuries!

Risk of damages to the machine!

Risk of damages to the environment!

- Make sure to follow all instructions described in this manual.

The machine is intended for the suction of air and other dry, non-aggressive, non-toxic and non-explosive gases.

Conveying of other media leads to an increased thermal and/or mechanical load on the machine and is permissible only after a consultation with Busch.

The machine is intended for the placement in a non-potentially explosive environment.

The machine is designed for indoor installation, in case of outdoor installation, ask your Busch representative in order to take specific precautions.

The machine is capable of maintaining ultimate pressure, see *Technical Data* [→ 29].

The machine is suitable for continuous operation.

Note: The non-return valve (NRV) shouldn't be used as a non-return or shut off valve for the System. The non-return valve is only to protect the pump.

If the machine needs to be maintained after shutdown:

- Provide an additional manual or automatic operated non-return valve in the suction line.

Permitted environmental conditions, see *Technical Data* [→ 29].

2.3 Design Options

The design options described in the following chapters might be combined.

Please refer to the nameplate (NP) to identify the corresponding design option of your machine.

Design option	Codification	Example
Standard (no design option)	0	MM 1402 A V0
ATEX version *	E	MM 1402 A VE
Aqua version	A	MM 1402 A VA
Gas tight version	G	MM 1402 A VG

* ATEX-version machines have a separate dedicated 'ATEX Instruction Manual' document.

2.3.1 Gas Tight Version



WARNING

Media potentially dangerous.

Risk of poisoning!

Risk of infection!

- Wear appropriate personal protective equipment in case of high concentration of the medium in the ambient atmosphere of the machine.

The gas tight version is a design option for applications where the process gas remains in the machine and does not escape to the environment.

It is a very important feature for applications where gases potentially dangerous to human health are not allowed and the concentration of the process gas must not exceed the admissible values of the ambient atmosphere of the machine.

This machine is specifically equipped with:

- pressure relief lines
- collecting lines
- shaft seal rings

Requirements for a proper functioning:

Ambient pressure	The gas tight machine requires an ambient pressure at the gas discharge during the whole operation range of +/- 200 hPa (mbar), unless otherwise specified on the nameplate.
Leakage rate	The machine is not absolutely gas tight. The leakage rate of the machine described in this manual is of 0.1 hPa l/s (mbar l/s) at a suction pressure of 250 mbar. It can considerably increase up to prohibited pressure values at the gas inlet/outlet due to used shaft seal rings or clogged pressure relief lines.
Ambient environment	Closed air cooling systems are not suitable and therefore prohibited. <ul style="list-style-type: none"> • Make sure that the machine is sufficiently vented (see <i>Installation Conditions</i> [→ 10]).

2.3.2 Aqua Version

The Aqua version is a design option for conveying condensable vapors (water).

This machine is specifically equipped with:

- corrosion protection coating
- optional condensate drain (CD) in the internal silencer.

2.4 Start Controls

The machine comes without start controls. The control of the machine is to be provided in the course of installation.

The machine can be equipped with a soft-starter.

2.5 Standard Features

2.5.1 Vacuum Relief Valve

The ultimate pressure is limited by a vacuum relief valve (VRE). The vacuum relief valve is adjusted ex-works to the minimum permitted ultimate pressure shown on the nameplate (NP).

2.6 Optional Accessories

2.6.1 Inlet Filter

The inlet filter protects the machine against dust and other solids in the process gas. The inlet filter is available with a paper or polyester cartridge.

2.6.2 Condensate Drain

The condensate drain (CD) uses to drain the accumulated fluids.

3 Transport



WARNING

Suspended load.

Risk of severe injury!

- Do not walk, stand or work under suspended loads.



WARNING

Lifting the machine using the motor eye bolt.

Risk of severe injury!

- Do not lift the machine using the eye bolt fitted to the motor. Only lift the machine as shown.
- To find out the weight of the machine, refer to the chapter *Technical Data* [→ 29] or the name-plate (NP).
- Make sure that the eye bolt(s) (EB) is/are in faultless condition, fully screwed in and tightened by hand.

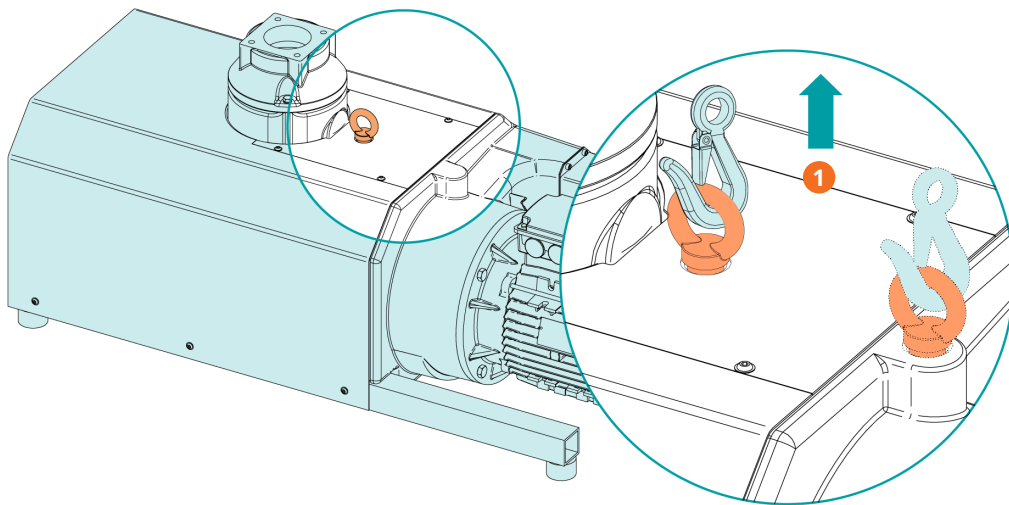

Description

1	Use both eye bolts, in case a second eye bolt is mounted!		
---	---	--	--

- Check the machine for transport damage.

If the machine is secured to a base plate:

- Remove the machine from the base plate.

4 Storage

- Seal all apertures with adhesive tape or reuse provided caps.

If the machine is to be stored for more than 3 months:

- Wrap the machine in a corrosion inhibiting film.
- Store the machine indoors, dry, dust free and if possible in original packaging preferably at temperatures between 0 ... 40 °C.

5 Installation

5.1 Installation Conditions



WARNING

Gas tight version:

The machine is not absolutely gas tight, possible leakages of dangerous media.

Risk of poisoning!

Risk of infection!

- Make sure that the ambient atmosphere of the machine is sufficiently ventilated. Closed air cooling systems are not suitable and therefore prohibited.



NOTICE

Use of the machine outside of the permitted installation conditions.

Risk of premature failure!

Loss of efficiency!

- Take care that the installation conditions are fully complied with.

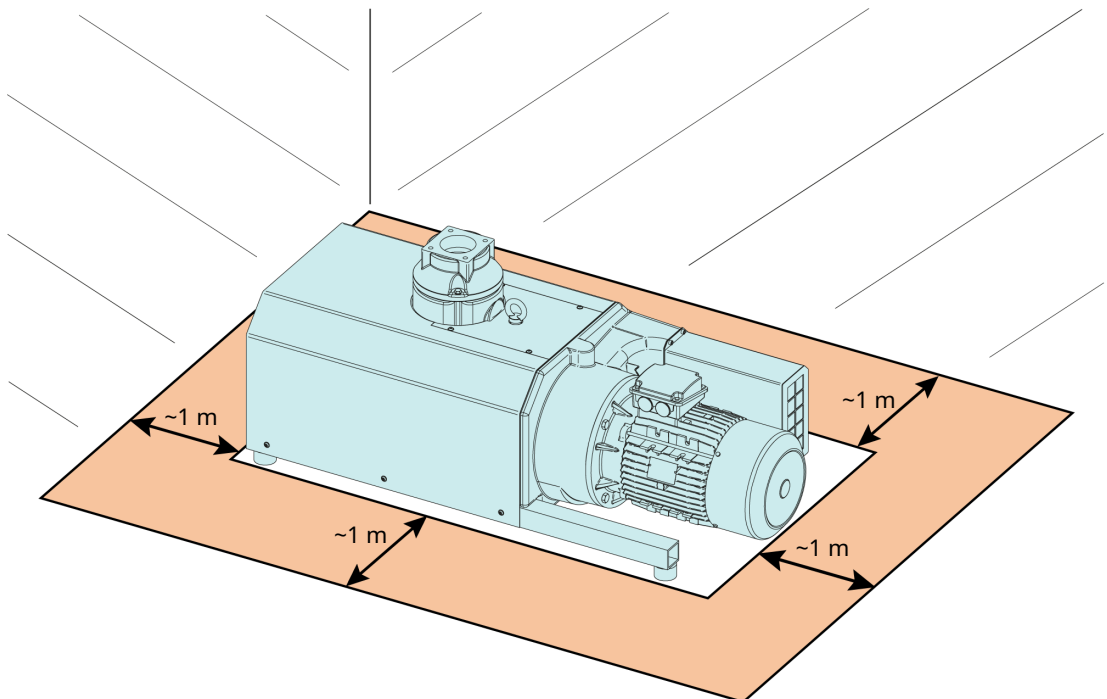

- Make sure that the environment of the machine is not potentially explosive.
- Make sure that the ambient conditions comply with the *Technical Data* [→ 29].
- Make sure that the environmental conditions comply with the protection class of the motor and the electrical elements.
- Make sure that the installation space or location is protected from weather and lightning.
- Make sure that the installation space or location is vented such that sufficient cooling of the machine is provided.

- Make sure that cooling air inlets and outlets are not covered or obstructed and that the cooling air flow is not affected adversely in any other way.
- Make sure that the oil sight glass (OSG) remains easily visible.
- Make sure that enough space remains for maintenance work.
- Make sure that the machine is placed or mounted horizontally, a maximum deviation of 1° in any direction is acceptable.
- Check the oil level, see *Oil Level Inspection* [→ 19].
- Make sure that all provided covers, guards, hoods, etc. are mounted.

If the machine is installed at an altitude greater than 1000 meters above sea level:

- Contact your Busch representative, the motor should be derated or the ambient temperature limited.

5.2 Connecting Lines / Pipes



WARNING

Rotating Parts.

Risk of severe injury!

- Do not operate the machine without suction / discharge connection installed.

- Remove all protective covers before installation.
- Make sure that the connection lines cause no stress on the connection of the machine; if necessary use flexible joints.
- Make sure that the line size of the connection lines over the entire length is at least as large as the connections of the machine.

In case of long connection lines, it is advisable to use larger line sizes in order to avoid a loss of efficiency. Seek advice from your Busch representative.



NOTICE

Flow of potential condensate from the piping to the vacuum pump.

Risk of damage to the machine!

- Make sure that the vacuum pump suction and exhaust connection pipes are installed in such a way as to prevent the flow of potential condensate from the piping to the vacuum pump.
- Busch recommends the use of the optional horizontal inlet filter and the water separator to collect the condensate and prevent it from flowing into the pump.

5.2.1 Suction Connection

NOTICE

Ingress of foreign objects or liquids.

Risk of damage to the machine!

If the inlet gas contains dust or other foreign solid particles:

- Install a suitable filter (5 micron or less) upstream from the machine.
-

Connection size(s):

- G3"

Depending on the specific configuration ordered, other connection dimensions may apply.

5.2.2 Discharge Connection

NOTICE

Discharge gas flow obstructed.

Risk of damage to the machine!

- Make sure that the discharged gas will flow without obstruction. Do not shut off or throttle the discharge line or use it as a pressurized air source.
-

Connection size(s):

- R2

Depending on the specific configuration ordered, other connection dimensions may apply.

Unless the aspirated air is discharged to the environment right at the machine:

- Make sure that the discharge line either slopes away from the machine or provide a liquid separator or a siphon with a drain cock, so that no liquids can flow back into the machine.

5.3 Filling Oil

! NOTICE

Use of an inappropriate oil.

Risk of premature failure!

Loss of efficiency!

- Only use an oil type which has previously been approved and recommended by Busch.

For oil type and oil capacity see *Technical Data* [→ 29] and *Oil* [→ 30].

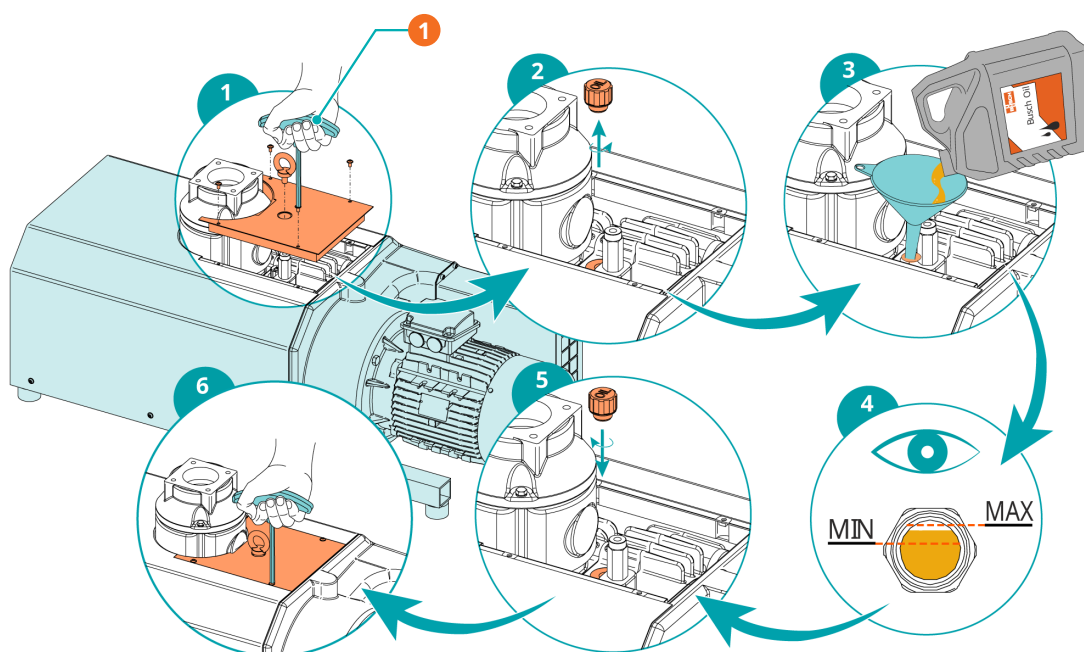

Description

1	4 mm hex key		
---	--------------	--	--

The oil level should stay constant over the lifetime of the oil. If the level does fall, this indicates a leak and the machine requires repair.

6 Electrical Connection



DANGER

Live wires.

Risk of electrical shock.

- Electrical installation work must only be executed by qualified personnel.

CURRENT PROTECTION OF THE CUSTOMER INSTALLATION:



DANGER

Missing current protection.

Risk of electrical shock.

- Current protection according to EN 60204-1 must be insured by the customer on its installation.
- The electrical installation must comply with the applicable national and international standards.

6.1 Machine delivered without Control Box or Variable Speed Drive (VSD)



DANGER

Live wires.

Risk of electrical shock.

- Electrical installation work must only be executed by qualified personnel.
- Make sure that the power supply for the motor is compatible with the data on the nameplate of the motor.
- If the machine is equipped with a power connector, install a residual current protective device to protect persons in case of isolation default.
 - Busch recommends installing a type B residual protective device suitable for the electrical installation.
- Provide a lockable disconnect switch or an emergency stop switch on the power line so that the machine is completely secured in case of an emergency situation.
- Provide a lockable disconnect switch on the power line so that the machine is completely secured during maintenance tasks.
- Provide an overload protection according to EN 60204-1 for the motor.
 - Busch recommends installing a D-curve circuit breaker.
- Connect the protective earth conductor.
- Electrically connect the motor.

NOTICE

Incorrect connection.

Risk of damage to the motor!

- The wiring diagrams given below are typical. Check the inside of the terminal box for motor connection instructions/diagrams.

6.2 Wiring Diagram Three-Phase Motor

NOTICE

Incorrect direction of rotation.

Risk of damage to the machine!

- Operation in the wrong direction of rotation can destroy the machine in a short time! Prior to start-up, ensure that the machine is operated in the right direction.

- Determine the intended direction of rotation with the arrow (stuck on or cast).
- Jog the motor briefly.

If the rotation of the motor must be changed:

- Switch any two of the motor phase wires.

Delta connection (low voltage):

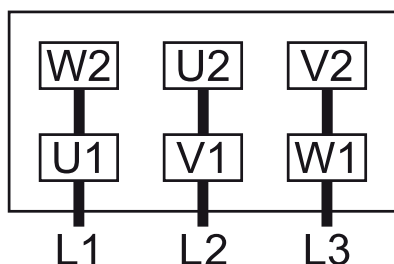

Star connection (high voltage):

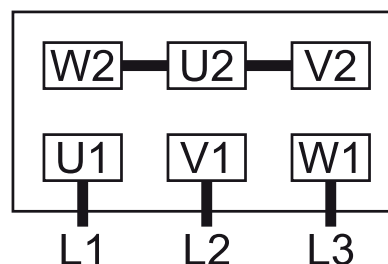

Double star connection, multi-voltage motor with 9 pins (low voltage):

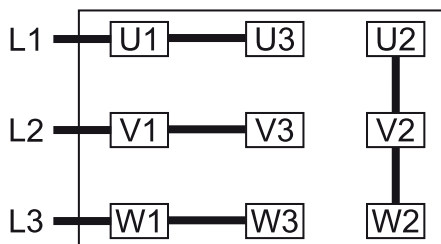

Star connection, multi-voltage motor with 9 pins (high voltage):

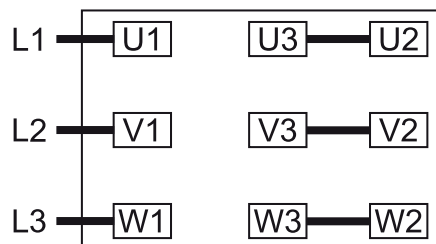

Double star connection, multi-voltage motor with 12 pins (low voltage):

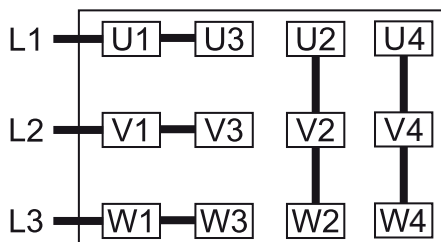

Star connection, multi-voltage motor with 12 pins (high voltage):

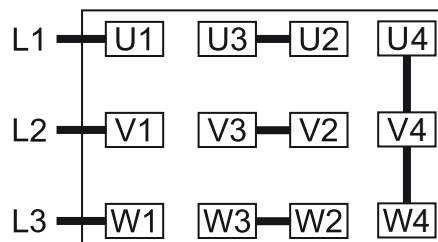

Delta connection, multi-voltage motor
with 12 pins (middle voltage):

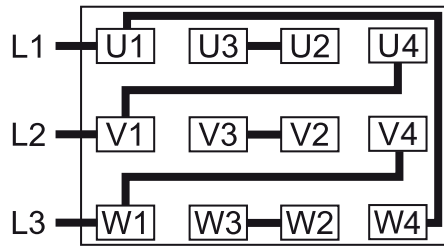

7 Commissioning

NOTICE

Lubricating a dry running machine (compression chamber).

Risk of damage to the machine!

- Do not lubricate the compression chamber of the machine with oil or grease.



CAUTION

During operation the surface of the machine may reach temperatures of more than 70°C.

Risk of burns!

- Avoid contact with the machine during and directly after operation.

CAUTION



Noise of running machine.

Risk of damage to hearing!

If persons are present in the vicinity of a non noise insulated machine over extended periods:

- Make sure to wear hearing protection.
- Make sure that the *Installation Conditions* [→ 10] are met.
- Start the machine.
- Make sure that the maximum permissible number of starts does not exceed 12 starts per hour. Those starts should be spread within the hour.
- Make sure that the operating conditions comply with the *Technical Data* [→ 29].

As soon as the machine is operated under normal operating conditions:

- Measure the motor current and record it as reference for future maintenance and trouble-shooting work.

7.1 Conveying Condensable Vapors

The Aqua version is a design option for conveying condensable vapors (water).

Water vapor within the gas flow is tolerated within certain limits. The conveyance of other vapors shall be agreed upon with Busch.

If condensable vapors are to be conveyed:

Before process:

- Warm up the machine for approximately half an hour.

After process:

- Operate the machine for approximately another half an hour.
- Regularly drain condensate from the silencer with the drain cock.

8 Maintenance



DANGER

Live wires.

Risk of electrical shock.

- Electrical installation work must only be executed by qualified personnel.



WARNING



Machines contaminated with hazardous material.

Risk of poisoning!

Risk of infection!

If the machine is contaminated with hazardous material:

- Wear appropriate personal protective equipment.



CAUTION

Hot surface.

Risk of burns!

- Prior to any action requiring touching the machine, let the machine cool down first.



CAUTION

Failing to properly maintain the machine.

Risk of injuries!

Risk of premature failure and loss of efficiency!

- Maintenance work must only be executed by qualified personnel.
- Respect the maintenance intervals or ask your Busch representative for service.



NOTICE

Using inappropriate cleaners.

Risk of removing safety stickers and protective paint!

- Do not use incompatible solvents to clean the machine.

- Shut down the machine and lock against inadvertent start up.
- Vent the connected lines to atmospheric pressure.

If necessary:

- Disconnect all connections.

8.1 Maintenance Schedule

The maintenance intervals depend very much on the individual operating conditions. The intervals given below are considered as starting values which should be shortened or extended as appropriate. Particularly harsh applications or heavy duty operation, such as high dust loads in the environment or in the process gas, other contamination or ingress of process material, can make it necessary to shorten the maintenance intervals significantly.

Interval	Maintenance work
Monthly	<ul style="list-style-type: none"> Check the inlet screen, clean if necessary. In case of an inlet filter (IF) being installed: <ul style="list-style-type: none"> Check the inlet filter cartridge, replace if necessary.
Every 3 months	<ul style="list-style-type: none"> Check the oil level, see <i>Oil Level Inspection</i> [→ 19].
Every 6 months	<ul style="list-style-type: none"> Clean the machine from dust and dirt. In case of a coupling (CPL) being installed: <ul style="list-style-type: none"> Check the coupling (CPL) for backlash and wear.
Gas tight version only Every 5000 hours or after 2 years	Depending on the requirements in terms of gas tightness: <ul style="list-style-type: none"> Replace sealing rings (contact Busch).
Gas tight version only Every 10000 hours or after 2 years	<ul style="list-style-type: none"> Check that pressure relief lines (PRL) are not clogged, see <i>Pressure Relief Lines Maintenance (Gas Tight Version Only)</i> [→ 22].
Every 20000 hours	<ul style="list-style-type: none"> Change the oil. The change interval of 20000 operating hours is valid for Busch approved oils only. The change interval depends very much on the operating conditions. Borderline operation may reduce the change interval down to approximately 5000 operating hours. Other oils may reduce the change interval.
Every 6 years	<ul style="list-style-type: none"> Have a major overhaul on the machine (contact Busch).

8.2 Oil Level Inspection

- Shut down the machine.
- When the machine is stopped, wait 1 minute before checking the oil level.

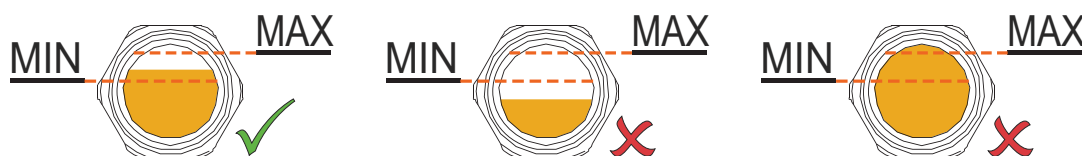

The oil level should stay constant over the lifetime of the oil. If the level does fall, this indicates a leak and the machine requires repair.

- Fill up if necessary, see *Oil Filling* [→ 13].

8.3 Cleaning from Dust and Dirt

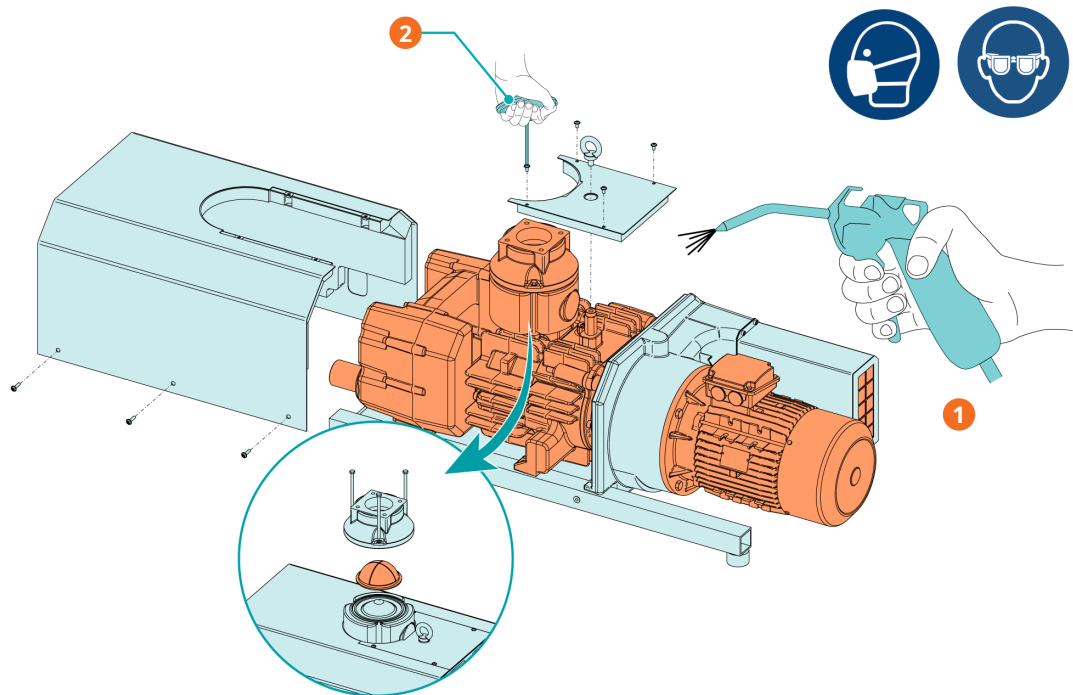

Description			
1	Clean the ventilation grid, fans, cooling fins and inlet screen (IS)	2	4 mm hex key

8.4 Oil Change

NOTICE

Use of an inappropriate oil.

Risk of premature failure!

Loss of efficiency!

- Only use an oil type which has previously been approved and recommended by Busch.

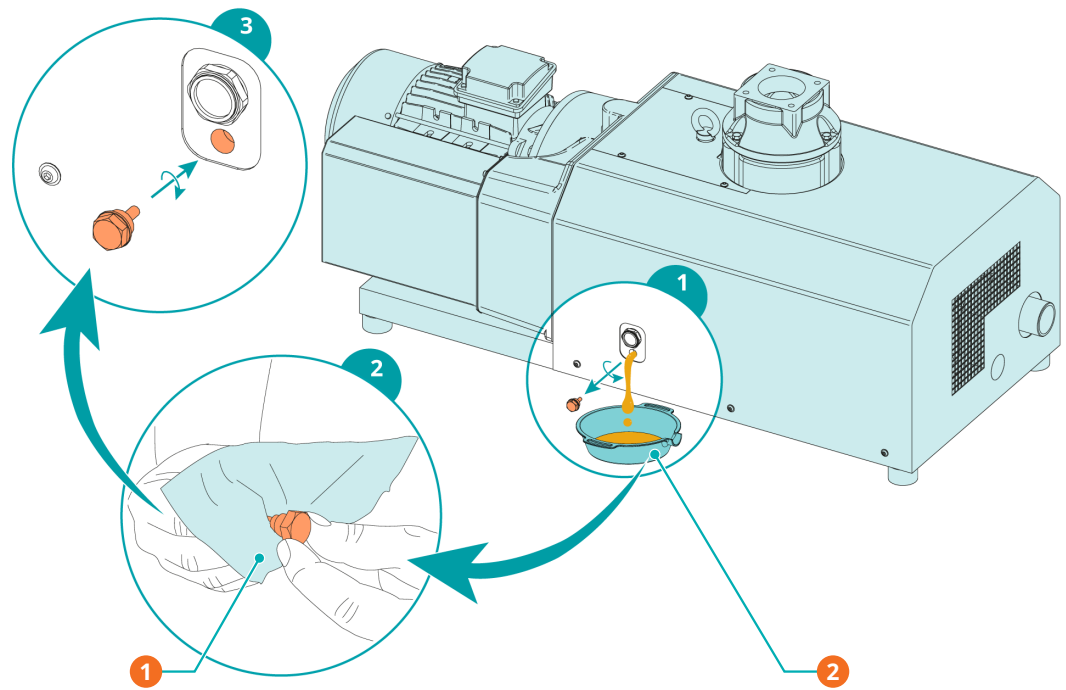

Description	
1	Cleaning cloth
2	Drain pan

For oil type and oil capacity see *Technical Data* [→ 29] and *Oil* [→ 30].

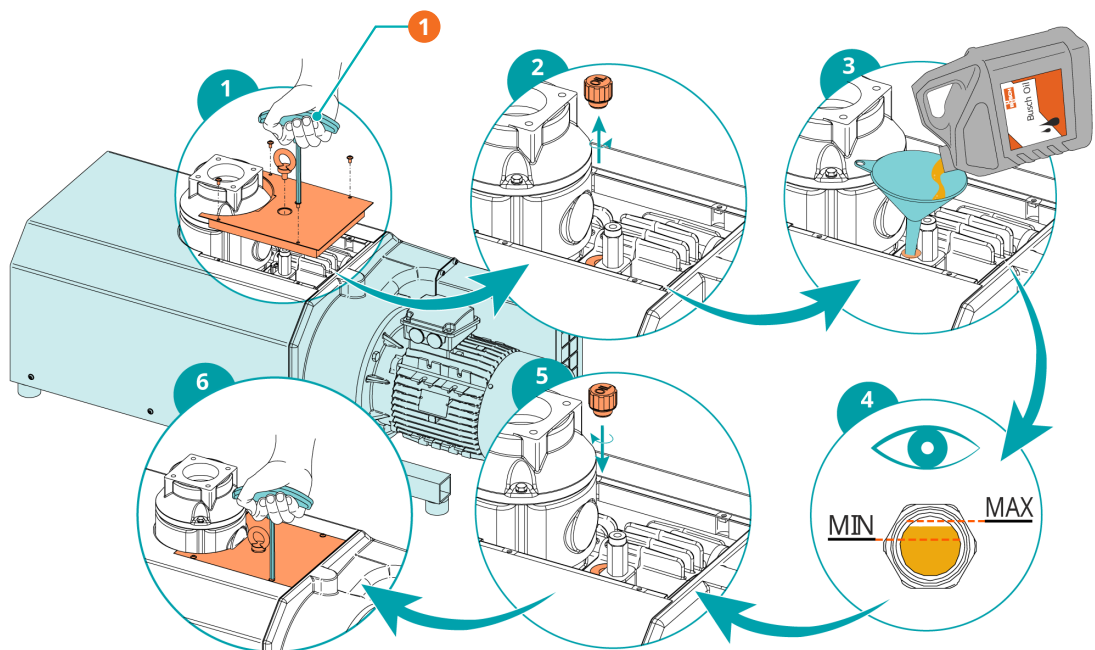

Description	
1	4 mm hex key

The oil level should stay constant over the lifetime of the oil. If the level does fall, this indicates a leak and the machine requires repair.

8.5 Pressure Relief Lines Maintenance (Gas Tight Version Only)



WARNING



Media potentially dangerous.

Risk of poisoning!

Risk of infection!

- Wear appropriate personal protective equipment in case of high concentration of the medium in the ambient atmosphere of the machine.

- Check that pressure relief lines (PRL) are not clogged as described in the following illustrations.

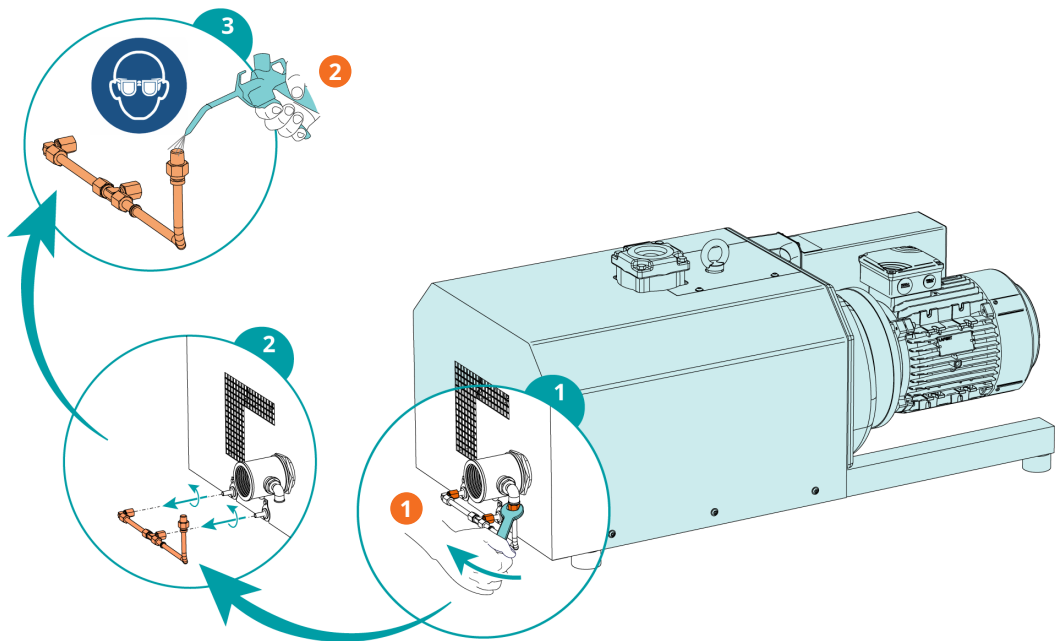

Description	
1	Unscrew nuts
2	Blow into the pipe

NOTICE

Pressurized air systems supply too high pressure.

Risk of damage to the machine!

- Adjust the pressurized air to 0.2 bar(g) by means of a pressure regulator.

In case of clogged pressure relief lines (PRL):

- Remove the clogging or have the machine repaired (contact Busch).

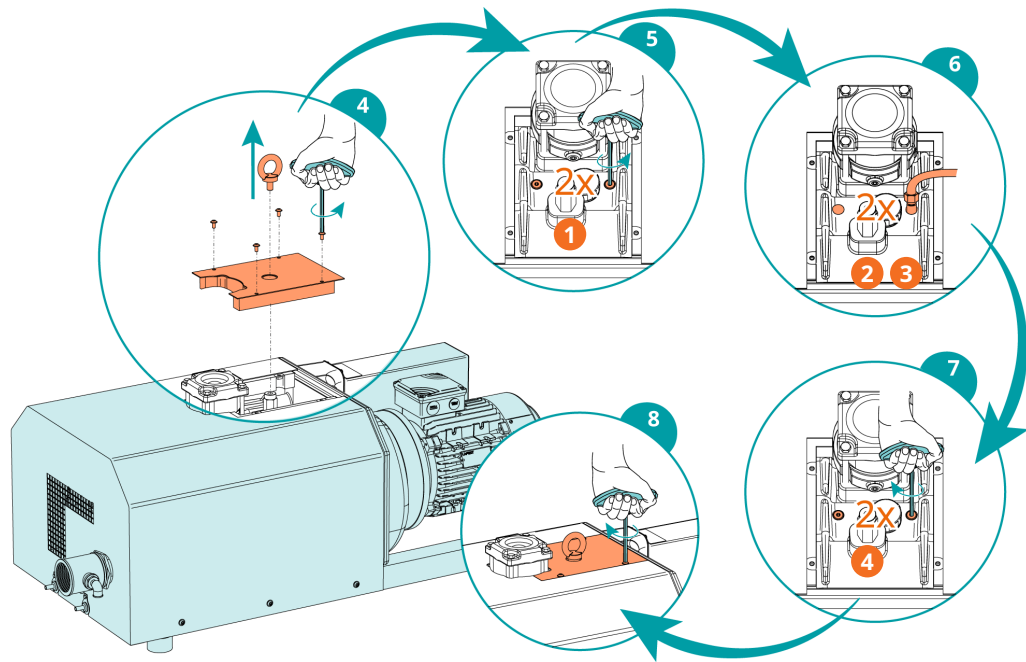

Description			
1	Unscrew plugs	2	Connect pressurized air to the pressure relief lines
3	Air pressure max. 0.2 bar (g)	4	Tighten plugs

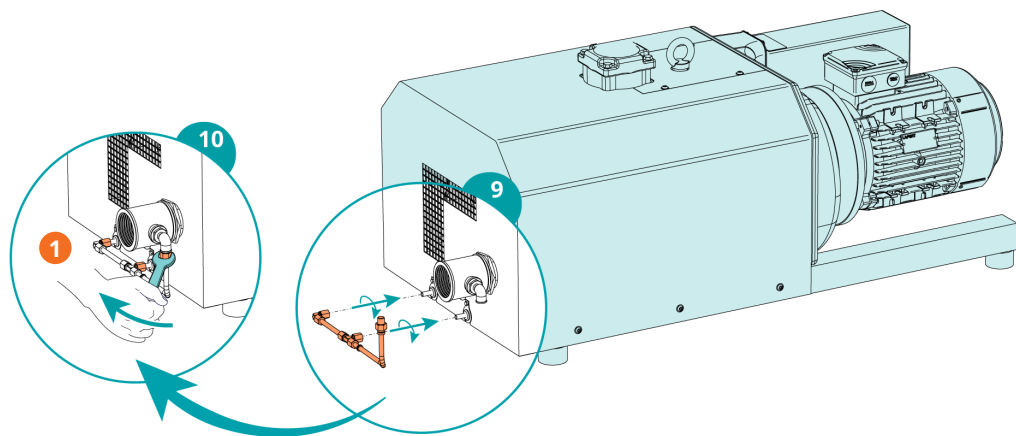

Description			
1	Tighten nuts		

9 Overhaul



WARNING



Machines contaminated with hazardous material.

Risk of poisoning!

Risk of infection!

If the machine is contaminated with hazardous material:

- Wear appropriate personal protective equipment.



NOTICE

Improper assembly.

Risk of premature failure!

Loss of efficiency!

- Any dismantling of the machine that goes beyond anything that is described in this manual should be done by Busch authorized technicians.

In case of the machine having conveyed gas that was contaminated with foreign materials which are dangerous to health:

- Decontaminate the machine as much as possible and state the contamination status in a 'Declaration of Contamination'.

Busch will only accept machines that come with a completely filled in and legally binding signed 'Declaration of Contamination' (form downloadable from www.buschvacuum.com).

10 Decommissioning



DANGER

Live wires.

Risk of electrical shock.

- Electrical installation work must only be executed by qualified personnel.



CAUTION

Hot surface.

Risk of burns!

- Prior to any action requiring touching the machine, let the machine cool down first.
- Shut down the machine and lock against inadvertent start up.
- Disconnect the power supply.
- Vent the connected lines to atmospheric pressure.
- Disconnect all connections.

If the machine is going to be stored:

- See *Storage* [→ 9].

10.1 Dismantling and Disposal

- Drain and collect the oil.
- Make sure that no oil drips onto the floor.
- Separate special waste from the machine.
- Dispose of special waste in compliance with applicable regulations.
- Dispose of the machine as scrap metal.

11 Spare Parts



NOTICE

Use of non-Busch genuine spare parts.

Risk of premature failure!

Loss of efficiency!

- The exclusive use of Busch genuine spare parts and consumables is recommended for the correct functioning of the machine and to validate the warranty.

Spare part	Description	Part no.
Oil fill plug (=Venting valve)	Includes appropriate seal ring	0543 138 026
Oil sight glass (OSG)		0583 000 001
Seal ring	For oil sight glass	0480 202 576
Oil drain plug (ODP)	Includes appropriate seal ring	0415 134 870
Seal ring	For oil drain plug	0482 137 352
Inlet flange lower part	Includes non-return valve	0916 000 672
Inlet screen (IS)		0534 000 094

If other parts are required:

- Contact your Busch representative.

12 Troubleshooting



DANGER

Live wires.

Risk of electrical shock.

- Electrical installation work must only be executed by qualified personnel.



CAUTION

Hot surface.

Risk of burns!

- Prior to any action requiring touching the machine, let the machine cool down first.

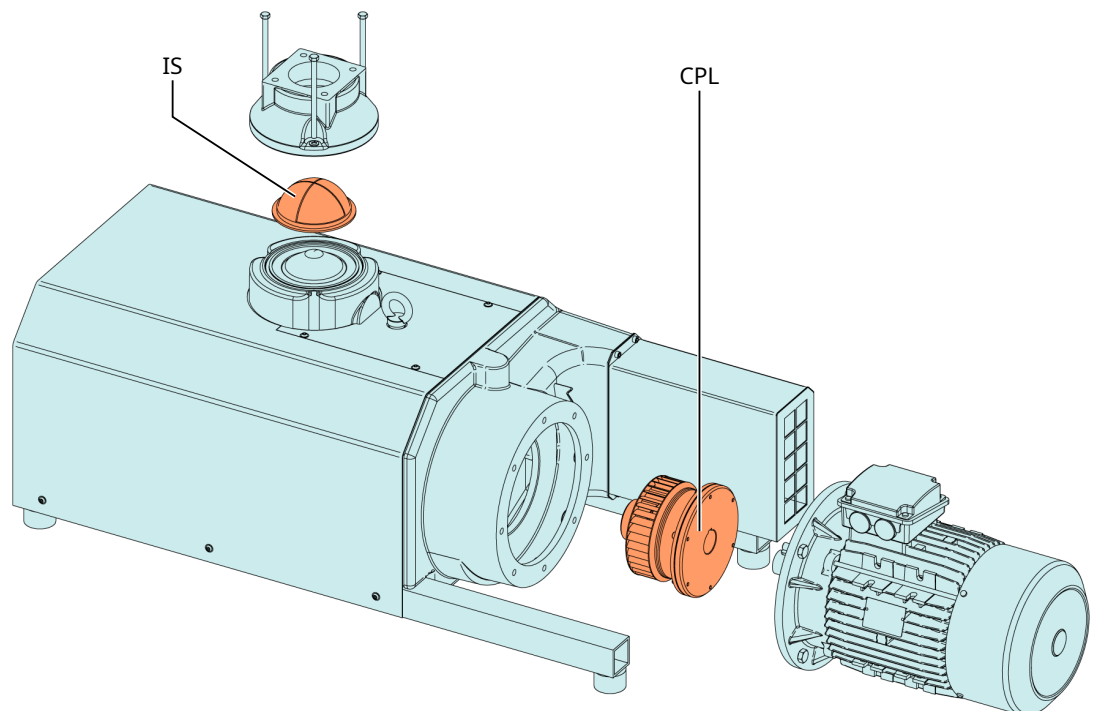

Description

IS	Inlet screen	CPL	Coupling
----	--------------	-----	----------

Problem	Possible Cause	Remedy
The machine does not start.	The motor is not supplied with the correct voltage.	• Check the power supply.
	The motor is defective.	• Replace the motor.
	The coupling (CPL) is defective.	• Replace the coupling (CPL).

Problem	Possible Cause	Remedy
The machine does not reach the usual pressure on the suction connection.	The inlet screen (IS) is partially clogged.	<ul style="list-style-type: none"> • Clean the inlet screen (IS).
	The inlet filter cartridge (optional) is partially clogged.	<ul style="list-style-type: none"> • Replace the inlet filter cartridge.
	Internal parts are worn or damaged.	<ul style="list-style-type: none"> • Repair the machine (contact Busch).
The machine runs very noisily.	Worn coupling (CPL).	<ul style="list-style-type: none"> • Replace the coupling (CPL).
	Oil level too low.	<ul style="list-style-type: none"> • Top up oil.
	Defective bearings.	<ul style="list-style-type: none"> • Repair the machine (contact Busch).
The machine runs too hot.	Insufficient cooling.	<ul style="list-style-type: none"> • Remove dust and dirt from the machine .
	The cooling fan's rotation direction is incorrect.	<ul style="list-style-type: none"> • Check the rotation direction of the cooling fan, if needed switch any one of the two power supply wires.
	Ambient temperature too high.	<ul style="list-style-type: none"> • Observe the permitted ambient temperature, see <i>Technical Data</i> [→ 29].
	Temperature of the process gases at the inlet too high.	<ul style="list-style-type: none"> • Observe the permitted gas inlet temperature, see <i>Technical Data</i> [→ 29].
	Oil level too low.	<ul style="list-style-type: none"> • Top up oil.

For resolution of problems not listed in the troubleshooting table, please contact your Busch representative.

13 Technical Data

		MM 1402 AV	MM 1502 AV
Nominal pumping speed (50Hz / 60Hz)	m ³ /h ACFM	400 / 470 - / 277	500 / 600 - / 353
Ultimate pressure	hPa (mbar) abs./ Torr abs.	200 150	
Nominal motor rating (50Hz / 60Hz)	kW hp	7.5 / 9.5 - / 12	11.0 / 12.6 - / 15
Nominal motor speed	min ⁻¹ RPM	3000 / 3600	
Permitted motor speed range	min ⁻¹ RPM	1200 ... 3600 ► ≥200 hPa (mbar) abs.	
Noise level (EN ISO 2151) at 400 hPa (mbar) abs. suction pressure (50Hz / 60Hz)	dB(A)	79 / 83	80 / 86
Ambient temperature range	°C °F	0 ... 40* 32 ... 104*	
Inlet gas temperature range	°C °F	0 ... 40* 32 ... 104*	
Ambient pressure		Atmospheric pressure	
Oil capacity	L Qts	1.2	
Weight approx. (50Hz / 60Hz)	Kg lbs	~ 290 / 320 - / ~705	~ 325 ~716

* In case of higher or lower temperatures, please consult your Busch representative.

14 Oil

	VS 150	VS 100
ISO-VG	150	100
Part number 1 L packaging	0831 164 883	0831 168 351
Part number 5 L packaging	0831 164 884	0831 168 352
Remark	3	4

1 = Single-phase motor; 2 = Three-phase motor; 3 = Standard oil for non-demanding applications; 4 = Food applications (H1); 5 = Anti-corrosion; 6 = Suitable for continuous operation; 7 = Not suitable for continuous operation; 8 = Improved air separation properties; 9 = Light cycle operation; 10 = Heavy duty cycle operation; 11 = Standard application up to 90°C; 12 = Suitable for Harsh application; 13 = Standard application up to 80°C

To know which oil has been filled in the machine, please refer to the nameplate (NP).

15 EU Declaration of Conformity

This Declaration of Conformity and the CE-markings affixed to the nameplate are valid for the machine within the Busch scope of delivery. This Declaration of Conformity is issued under the sole responsibility of the manufacturer.

When this machine is integrated into a superordinate machinery the manufacturer of the superordinate machinery (this can be the operating company, too) must conduct the conformity assessment process for the superordinate machine or plant, issue the Declaration of Conformity for it and affix the CE-marking.

The manufacturer is determined by the serial number:

Serial number starts with **CHM1...**

Ateliers Busch S.A.
Zone industrielle
2906 Chevez
Switzerland

Serial number starts with **USM1...**

Busch Manufacturing LLC
516 Viking Drive
Virginia Beach, VA 23452
USA

declares that the machine: MINK MM 1402 AV; MINK MM 1502 AV

fulfill(s) all the relevant provisions from EU directives:

- 'Machinery' 2006/42/EC
- 'Electromagnetic Compatibility' (EMC) 2014/30/EU
- 'RoHS' 2011/65/EU Restriction of the use of certain hazardous substances in electrical and electronic equipment (incl. all related applicable amendments)

and comply(-ies) with the following harmonized standards that have been used to fulfill those provisions:

Standards	Title of the Standard
EN ISO 12100 : 2010	Safety of machinery - Basic concepts, general principles of design
EN ISO 13857 : 2019	Safety of machinery - Safety distances to prevent hazard zones being reached by the upper and lower limbs
EN 1012-2 : 1996 + A1 : 2009	Vacuum pumps - Safety requirements - Part 2
EN ISO 2151 : 2008	Acoustics - Noise test code for compressors and vacuum pumps - Engineering method (grade 2)
EN 60204-1 : 2018	Safety of machinery - Electrical equipment of machines - Part 1: General requirements
EN IEC 61000-6-2 : 2019	Electromagnetic compatibility (EMC) - Generic standards. Immunity for industrial environments
EN IEC 61000-6-4 : 2019	Electromagnetic compatibility (EMC) - Generic standards. Emission standard for industrial environments

Legal person authorized to compile the technical file and authorized representative in the EU (if the manufacturer is not located in the EU):

Busch Dienste GmbH
 Schauinslandstr. 1
 DE-79689 Maulburg

Chevez, 2.01.2021

Virginia Beach, 2.01.2021



Christian Hoffmann
General Manager
Ateliers Busch S.A.



David Gulick
General Manager
Busch Manufacturing LLC

16 UK Declaration of Conformity

This Declaration of Conformity and the UKCA-markings affixed to the nameplate are valid for the machine within the Busch scope of delivery. This Declaration of Conformity is issued under the sole responsibility of the manufacturer.

When this machine is integrated into a superordinate machinery the manufacturer of the superordinate machinery (this can be the operating company, too) must conduct the conformity assessment process for the superordinate machine or plant, issue the Declaration of Conformity for it and affix the UKCA-marking.

The manufacturer is determined by the serial number:

Serial number starts with **CHM1...**

Ateliers Busch S.A.
Zone industrielle
2906 Chevenez
Switzerland

Serial number starts with **USM1...**

Busch Manufacturing LLC
516 Viking Drive
Virginia Beach, VA 23452
USA

declares that the machine: MINK MM 1402 AV; MINK MM 1502 AV

fulfill(s) all the relevant provisions from UK legislations:

- Supply of Machinery (Safety) Regulations 2008
- Electromagnetic Compatibility Regulations 2016
- Restriction of the use of certain hazardous substances in Electrical and Electronic Equipment Regulations 2021

and comply(-ies) with the following designated standards that have been used to fulfill those provisions:

Standards	Title of the Standard
EN ISO 12100 : 2010	Safety of machinery - Basic concepts, general principles of design
EN ISO 13857 : 2019	Safety of machinery - Safety distances to prevent hazard zones being reached by the upper and lower limbs
EN 1012-2 : 1996 + A1 : 2009	Vacuum pumps - Safety requirements - Part 2
EN ISO 2151 : 2008	Acoustics - Noise test code for compressors and vacuum pumps - Engineering method (grade 2)
EN 60204-1 : 2018	Safety of machinery - Electrical equipment of machines - Part 1: General requirements
EN IEC 61000-6-2 : 2019	Electromagnetic compatibility (EMC) - Generic standards. Immunity for industrial environments
EN IEC 61000-6-4 : 2019	Electromagnetic compatibility (EMC) - Generic standards. Emission standard for industrial environments

Legal person authorized to compile the technical file and importer in the UK
 (if the manufacturer is not located in the UK):

Busch (UK) Ltd
 30 Hortonwood
 Telford - UK

Chevenez, 2.01.2021

Virginia Beach, 2.01.2021



Christian Hoffmann
General Manager
Ateliers Busch S.A.

David Gulick
General Manager
Busch Manufacturing LLC

Notes

A large grid of small dots, intended for taking notes. The grid consists of approximately 30 columns and 40 rows of dots, providing a structured space for writing.





Busch

Vacuum Solutions

With a network of over 60 companies in more than 40 countries and agencies worldwide, Busch has a global presence. In every country, highly competent local personnel delivers custom-tailored support backed by a global network of expertise. Wherever you are. Whatever your business. We are there for you.

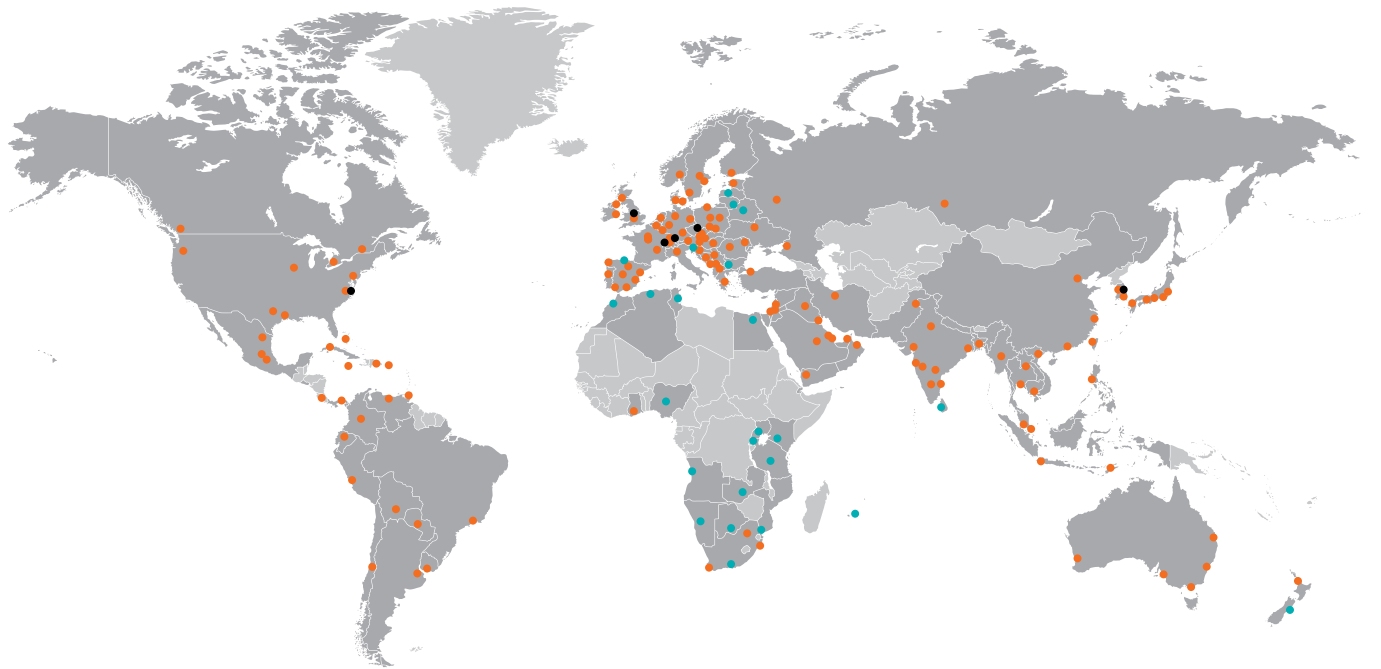

● Busch companies and Busch employees ● Local representatives and distributors ● Busch production site

www.buschvacuum.com