



SOLBERG
Filtration & Separation

Medical Vacuum Filtration

HV Series 1" - 4"

Application

Solberg's HV Series bacterial filters for medical vacuum service are designed to offer industry leading pressure drop performance and meet demanding filtration requirements in accordance with current European and US Medical Vacuum standards:

ISO 7396-1:2016 Medical gas pipeline systems — Part 1 Pipeline systems for compressed medical gases and vacuum

NFPA 99:2018 Health Care Facilities Code

With its exclusive transparent design, pleated element construction, maximized element surface area, and minimal pressure drop, the HV Series offers an innovative, high quality, and long lasting solution that satisfies the strict requirements of the medical industry.

Third party verification ensures Solberg's elements meet ISO 45 H classification as defined in ISO 29463-1. The HV Series achieves greater than 99.995% total retention rate offering a very high level of protection in medical/hospital, dental, and laboratory applications.

Benefits

- Minimizes microbial contamination of vacuum pump oil and surrounding environment
- Visual pressure differential indication allows for real time monitoring and maintenance checks of the filter
- Biohazard labels improve safety and awareness at facility
- Increased surface area and large collection area maximizes contaminant holding capacity
- Low pressure drop design for reduced energy consumption over time
- Corrosion resistant and heavy duty materials of construction offer high performance and extended service life
- Isolation valve allows for quick and easy change out of glass flask for sterilization or disposal
- Equipped with pressure differential gauge for visual indication to service filter
- Easily incorporated into the medical gas distribution system piping allowing for a CE marking according to the Medical Devices Directive 93/42/EC
- High efficiency elements tested and verified to meet EN1822-1 filter class H14 requirements
- Meets NFPA 99 Requirements for vacuum filtration



Rev: HV-US1807K

HV Series 1" - 4"

Technical Specifications

- Operating pressure range: atmospheric to full vacuum
- Particulate removal > 99.995% efficiency
- Meets ISO 29463-1 requirements for ISO 45H class filtration
- Temp (continuous): min -15°F (-26°C) max 220°F (104°C)
- Corrosion resistant aluminum cast head
- Shatter resistant polycarbonate collection area
- Glass drain flask for easy removal and sterilization

Gauge & Mounting Boss

- Available with or without gauge (standard HV part number includes gauge). For information on a unit without gauge, please contact the factory.
- Housings can be modified for mounting brackets by tapping the precast mounting bosses.

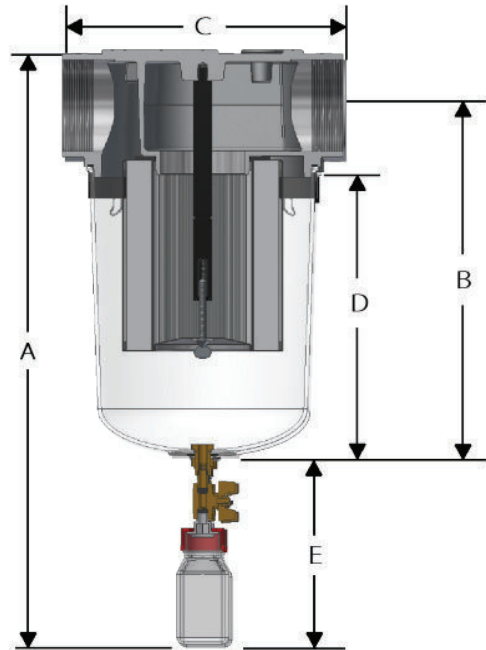

Inlet/Outlet Size	Type	Assembly Part Number (w/ Gauge)	Approx. Dimensions - inches					Approx. Weight lbs.	Replacement Element Part No.	Rarified Air Flow Rating At 19" HgV	Air Flow at Atmosphere: Free Air Aspirated (FAA)
			A	B	C	D	E				
1"	NPSC	HV-UL896-100C	22 1/2	12	7	10 3/8	9 1/4	15	UL896	110 CFM	40 SCFM
1 1/4"	NPSC	HV-UL896-125C	22 1/2	12	7	10 3/8	9 1/4	15	UL896	123 CFM	45 SCFM
1 1/2"	NPSC	HV-UL896-150C	22 1/2	12	7	10 3/8	9 1/4	15	UL896	123 CFM	45 SCFM
2"	NPSC	HV-UL850/1-200C	25 1/2	14 1/4	9	12 1/2	9 1/4	19	UL850/1	383 CFM	140 SCFM
2 1/2"	NPTF	HV-UL850/1-250C	25 1/2	14 1/4	9	12 1/2	9 1/4	19	UL850/1	383 CFM	140 SCFM
3"	NPTF	HV-UL234/2G-300C	29	17	13 1/2	14	9 1/4	30	UL234/2G	619 CFM	226 SCFM
4"	NPTF	HV-UL234/2G-400C	29	17	13 1/2	14	9 1/4	30	UL234/2G	619 CFM	226 SCFM

6" option available upon request.



SOLBERG

www.solbergmfg.com

All model offerings and design parameters are subject to change without prior notice. Contact your representative or Solberg for the most current information.